



DX140LCR

Engine Power : SAE J1349, net 81 kw(100 HP)@2,000 rpm

Operational Weight : 14,000kg (30,864 lb)-STD.

Bucket capacity(SAE): 0.24 ~0.76 m³ (0.31 ~0.99 cu.yd)



Hydraulic Excavator DX 140LCR

DX 140LCR



A New Model Doosan DX 140 LCR Hydraulic Excavator :

Novel Increased production and improved fuel economy is attributed to the electronic optimization of the hydraulic system and the new generation DOOSAN engine (Tier Stage). Improved ergonomics increases comfort and excellent all round visibility ensuring a safe and pleasant working environment. Improved reliability is achieved through the use of high performance materials combined with new methods of structural stress analysis, and leads to increased component life expectancy, thus reducing running costs. Reduced maintenance increases the availability and reduces operating costs of the excavator.



Performance



The performance of the DX 140 LCR has a direct effect on its productivity. Its new "Common Rail" engine and new e-EPOS controlled hydraulic system have combined to create an unbeatable hydraulic excavator, with a cost/performance ratio that makes the DX 140 LCR even more appealing.

DOOSAN DX 140LCR ENGINE

Maker & Model	Cummins QSB4.5 Diesel Engine
Rated Horse Power	Gross) 110PS @ 2,000 rpm (SAE J1349) Net) 100PS @ 2,000 rpm (SAE J1349)
Max. Torque	Gross) 46.7 kgf.m @ 1,400 rpm Net) 44.8 kgf.m @ 1,400 rpm
Performance Standard	KS-R1004
Power (Max, Rated)	100 PS / 1,800 rpm
Max. Torque	46.7 kg.m / 1,500 rpm
Fuel Consumption (Max, Rated)	171 g/kW.h

Reduced Tail Swing Radius

"It can be easily used in the city and tight locations, due to reducing the tail swing radius up to 33%."

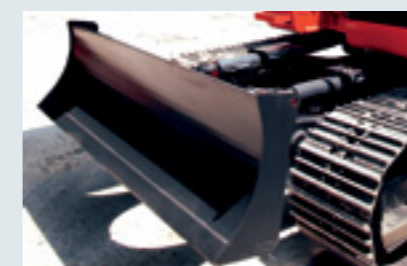

Machinery industry

Accumulated experience and business know-how established through the years as a leader of Korea's machinery industry,



Hydraulic Pump

The Main pump has a capacity of 2x114 /min(@2,000 rpm) reducing cycle time while a high capacity gear pump improves pilot line efficiency.

Swing Drive

Shocks during rotation are minimized, while increased torque is available to ensure rapid cycles.

Comfort

The work rate of the hydraulic excavator is directly linked to the performance of its operator. DOOSAN designed the DX 140 LCR by putting the operator at the center of the development goals. The result is significant ergonomic value that improves the efficiency and safety of the operator.



Control panel

More space, better visibility, air conditioning, a very comfortable seat... These are all elements that ensure the operator can work for hours and hours in excellent conditions.

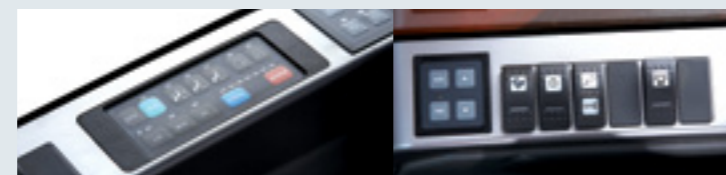

DX 140 LCR



Control stand (Telescopic Function)

Comfortable 2-stage sliding seat



Dozer Control (Optional)

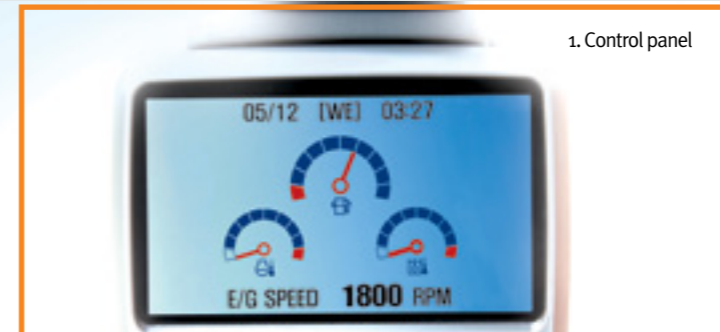

1. Control panel



2. Operation modes

Choice of operating modes

- Working mode**
 - Digging mode: for general excavation, loading, lifting...
 - Trenching mode: swing priority for trench work, canal digging, embankments...
- Power mode**
 - Standard: uses 85% engine power for all work
 - Power: uses 100% engine power for heavy work



Control lever

Very precise control of the equipment increases versatility, safety and facilitates tricky operations requiring great precision. Leveling operations and the movement of suspended loads are made easier and safer.

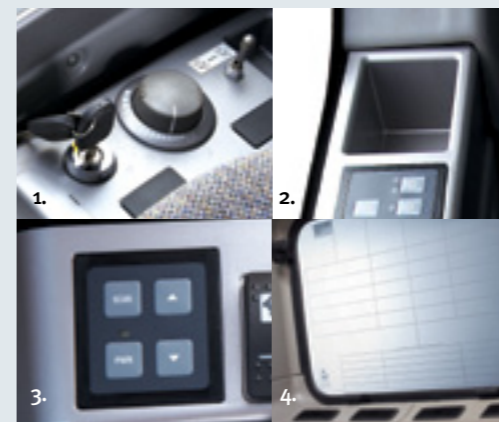

- 1. Cellular phone box
- 2. 12V Power socket
- 3. Cigarette lighter
- 4. Glass antenna

Rear Camera



Reliability & Maintenance

The reliability of a product contributes to its overall lifetime operating costs.

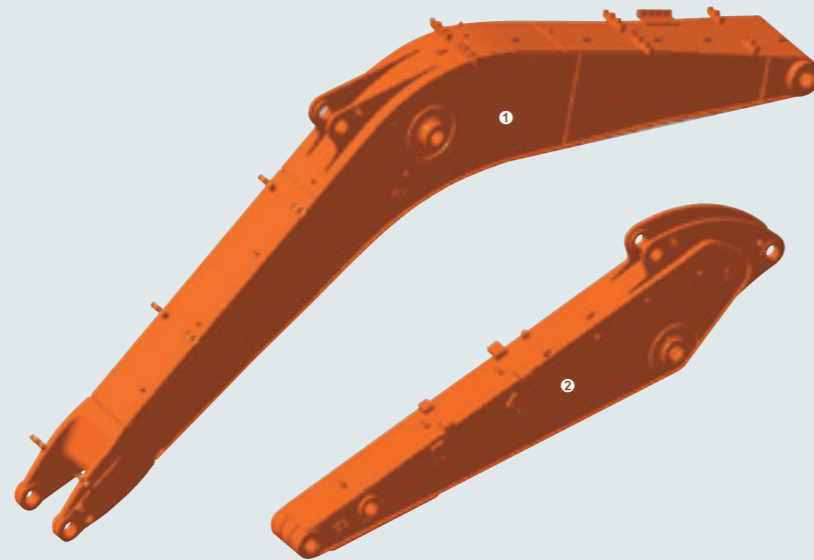

1 Strengthened Boom

The shape of the boom has been optimized by finite elements design, allowing uniform load distribution throughout the structure.

2 Arm Assembly

In the arm assembly greater strength has been gained by using cast elements and reinforcement around the bosses to give increased life.

Doosan uses computer-assisted design techniques, highly durable materials and a quality engineered structure. Our research and development engineers test all product under the most extreme conditions. Durability, reliability and product longevity are Doosan's top priorities.

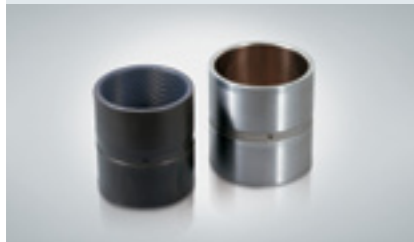

Bushing

A highly lubricated metal is used for the boom pivot in order to increase the lifetime and extend the greasing intervals to 250 hours.



Ultra-hard wear-resistant disc

New materials have been used in order to increase the wear resistance and to increase the service intervals.



X-chassis

The X-chassis frame section has been designed using finite element and 3-dimensional computer simulation



Integrated Track Spring and Idler

The track spring and the idler have been joined directly to achieve high durability and improved maintenance convenience.

Tracks

The chain is composed of self-lubricating sealed links isolated from all external contamination.



Easy maintenance

Easy access to the various radiators and coolers makes cleaning easier. Access to the various parts of the engine is from the top and via side panels.



Engine oil filter

The engine oil filter offers a high level of filtration allowing the oil change interval to be increased to 500 hours.



Hydraulic oil return filter

The protection of the hydraulic system is more effective, using glass fiber filter technology in the main oil return filter.



Air cleaner

The large capacity forced air cleaner removes over 99% of airborne particles, reducing the risk of engine contamination and making the cleaning and cartridge change intervals greater.



Fuel pre-filter

High efficiency fuel filtration is attained by the use of multiple filters, including a fuel pre-filter fitted with a water separator that removes most moisture from the fuel.

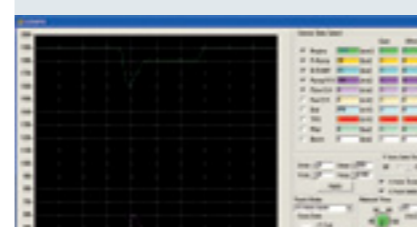

PC Monitoring (DMS)

A PC monitoring function enables connection to the e-EPOS system, allowing various parameters to be checked during maintenance



Convenient Fuse Box

The fuse box is conveniently located in a section of the storage compartment behind the operator's seat providing a clean environment and easy access.



Centralized grease inlets for easy maintenance

The arm grease inlets are grouped for easy access.

DX 140 LCR

DOOSAN has developed the DX 140 LCR profitability with end-user in mined. Easy maintenance operations at long intervals increase the availability of the equipment on site.

Technical Specification



Engine

MODEL

Cummins QSB 4.5
 “Common Rail” engine with direct fuel injection and electronic control, 4 valves per cylinder, vertical injectors, water cooled, turbo charged with air to air intercooler. The emission levels are well below the values required for phase III.

NUMBER OF CYLINDERS

4

NOMINAL FLYWHEEL POWER

81kW(100ps) @ 2,000 rpm

MAX TORQUE

458kgfm @ 1500rpm

PISTON DISPLACEMENT

4,500 cc

STARTER

24 V / 4.5 kW

BATTERIES

2 x 12 V / 100 Ah

AIR CLEANER

Double element with auto dust evacuation.

Hydraulic System

The heart of the system is the e-EPOS (Electronic Power Optimizing System). It allows the efficiency of the system to be optimized for all working conditions and minimizes fuel consumption. The new e-EPOS is connected to the engine electronic control via a data transfer link to harmonize the operation of the engine and hydraulics.

- The hydraulic system enables independent or combined operations.
- Two travel speeds offer either increased torque or high speed tracking.
- Cross-sensing pump system for fuel savings.
- Auto deceleration system.
- Two operating modes, two power modes.
- Button control of flow in auxiliary equipment circuits.
- Computer-aided pump power control.

MAIN PUMPS

2 variable displacement axial piston pumps
 max flow: 2 x 114 l / min (2 X 30.1 US gpm, 2 X 25.1 Imp gpm)

PILOT PUMP

Gear pump - max flow: 35 l / min

MAXIMUM SYSTEM PRESSURE

Boom/Arm/Bucket - Normal mode: 357 kgf/cm² (350 bar)
 Power mode - 350 kgf/cm² (343 bar)
 Travel - 357 kgf/cm² (350 bar)
 Swing - 275 kgf/cm² (270 bar)

MAIN RELIEF VALVES

boom arm bucket normal: 330, power 350 travel 350 rotation 270 bar

Weight

Boom 4,600 mm (15'1") / Arm 2,500 mm (8'2") / Bucket SAE 0.51 m³ (0.67 yd³)

Shoe width	Operating weight	Ground pressure (kgf/cm ²)
500 mm (1'8")	14,280 kg (31,482 lb)	0.43 kgf/cm ² (42 kpa, 6.11 psi)
600 mm (2")	14,480 kg (31,922 lb)	0.36 kgf/cm ² (35 kpa, 5.12 psi)
700 mm (2'4")	14,680 kg (32,363 lb)	0.30 kgf/cm ² (29 kpa, 4.26 psi)

WEIGHT WITH DOZER BLADE

STD. - Boom 4,600 mm (15'1") / Arm 2,500 mm (8'2") / Bucket SAE 0.51 m³ (0.67 yd³)

Shoe width	Dozer Blade weight	Operating weight
STD. + 500 mm (1'8")	2,500 mm : 590 kg (1,300 lb)	15,100 kg (33,289 lb)
STD. + 600 mm (2")	2,600 mm : 602 kg (1,327 lb)	15,300 kg (33,730 lb)
STD. + 700 mm (2'4")	2,700 mm : 615 kg (1,356 lb)	15,500 kg (34,171 lb)

※ When the dozer blade is installed, additional weight may be occurred by track frame, dozer cylinder, dozer unit, pin assembly, track shoe.

Hydraulic Cylinders

The piston rods and cylinder bodies are made of high-strength steel. A shock absorbing mechanism is fitted in all cylinders to ensure shock-free operation and extend piston life.

Cylinders	Quantity	Bore x Rod diameter x stroke
Boom	2	110 X 75 X 1,085mm(4.3" X 3.0" X 3'7")
Arm	1	115 X 80 X 1,108mm(4.5" X 3.1" X 3'8")
Bucket	1	100 X 70 X 900mm(3.9" X 2.8" X 2'11")

Undercarriage

Chassis are of very robust construction, all welded structures are designed to limit stresses. High-quality material used for durability. Lateral chassis welded and rigidly attached to the undercarriage. Track rollers lubricated for life, idlers and sprockets fitted with floating seals. Tracks shoes made of induction-hardened alloy with triple grouser. Heat-treated connecting pins. Hydraulic track adjuster with shock-absorbing tension mechanism.

NUMBER OF ROLLERS AND TRACK SHOES PER SIDE

Upper rollers: 1 / Lower rollers: 7 / Shoes: 46 /
 Total length of track: 3,755mm (12'4")

Environment

Noise levels comply with environmental regulations (dynamic values).

SOUND LEVEL GUARANTEE - 101 dB(A) (2000/14/EC)

CAB SOUND LEVEL - 72 dB(A) (ISO 6396)

Bucket

Capacity		Width		Weight	Recommendation				
					4,600mm (15'1") One-piece Boom			4,988 mm (16'4") Two-piece Boom	
PCSA, heaped	CECE heaped	Without side cutters	Width side cutters		2,100mm (6'11")Arm	2,500mm (8'2")Arm	3,000mm (9'10")Arm	2,100mm (6'11")Arm	2,500 mm (8'2")Arm
0.24m ³ (0.31 yd ³)	0.22m ³	468.4mm (1'6")	534.0mm (1'9")	294 kg (648 lb)	A	A	A	A	A
0.39m ³ (0.51 yd ³)	0.35m ³	736.4mm (2'5")	819.8mm (2'8")	362 kg (798 lb)	A	A	B	A	B
0.45m ³ (0.59 yd ³)	0.40m ³	823.8mm (2'8")	911.0mm (3')	402 kg (886 lb)	A	B	B	B	B
0.51m ³ (0.67 yd ³)	0.45m ³	907.4mm (3')	911.0mm (3'3")	418 kg (922 lb)	A	B	C	B	C
0.59m ³ (0.77 yd ³)	0.51m ³	997.4mm (3'3")	1,081.0mm (3'7")	439 kg (968 lb)	B	C	-	C	-
0.64m ³ (0.84 yd ³)	0.55m ³	1,083.4mm (3'7")	1,167.0mm (3'10")	465 kg (1,025 lb)	C	-	-	C	-

A. Suitable for materials with density of 2,000 kg/m³ (3,370 lb/CU yd) or less
 B. Suitable for materials with density of 1,600 kg/m³ (2,700 lb/CU yd) or less
 C. Suitable for materials with density of 1,100 kg/m³ (1,850 lb/CU yd) or less

Swing Mechanism

An axial piston motor with two-stage planetary reduction gear is used for the swing. Increased swing torque reduces swing time. Internal induction-hardened gear. Internal gear and pinion immersed in lubricant bath. The swing brake for parking is activated by spring and released hydraulically.

SWING SPEED - 0 to 10.7 rpm

Drive

Each track is driven by an independent axial piston motor through a planetary reduction gearbox. Two levers with control pedals guarantee smooth travel with counterrotation on demand.

TRAVEL SPEED (FAST/SLOW) - 5.0 / 3.0 km/h

DRAWBAR PULL - 12,500 kg (27,560 ldf)

MAXIMUM GRADE - 35° / 70%

Refill Capacities

FUEL TANK - 234 l (61.8 US gal, 51.0 Imp gal)

COOLING SYSTEM (RADIATOR CAPACITY) - 18 l (4.7 US gal, 4.0 Imp gal)

ENGINE OIL - 11 l (2.9 US gal, 2.4 Imp gal)

SWING DRIVE - 3.8 l (1.0 US gal, 0.8 Imp gal)

FINAL DRIVE (EACH) - 3 l (0.8 US gal, 0.6 Imp gal)

HYDRAULIC SYSTEM - 133 l (35.1 US gal, 29.2 Imp gal)

HYDRAULIC TANK - 93.5 l (24.7 US gal, 20.5 Imp gal)

Dimensions

One - Piece Boom

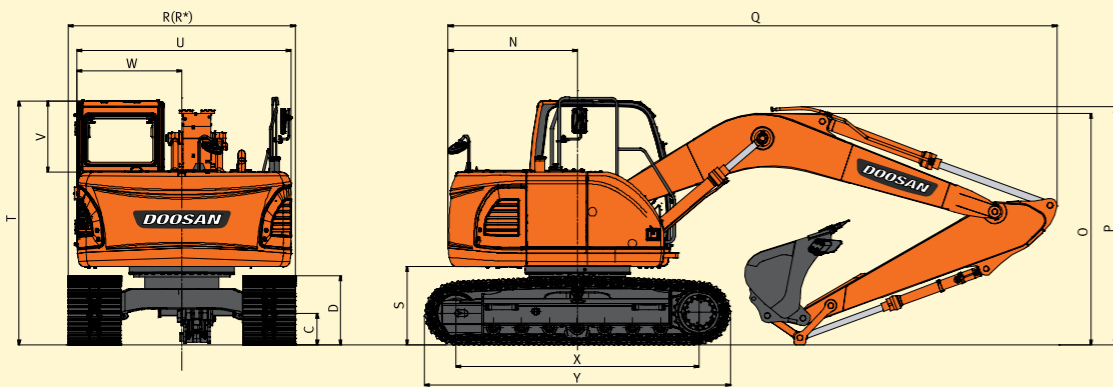

BOOM TYPE	(mm)	(ONE PIECE) 4600		
ARM TYPE	(mm)	2100	2500	3000
BUCKET TYPE (SAE)	(m ³)	0.51	0.51	0.39
TAIL SWING RADIUS	(mm) N	1480	-	-
SHIPPING HEIGHT (BOOM)	(mm) O	2520	2630	3030
SHIPPING HEIGHT (HOSE)	(mm) P	2585	2710	3094
SHIPPING LENGTH	(mm) Q	7245	7230	7195
SHIPPING WIDTH	(mm) R	2590	-	-
C/WEIGHT CLEARANCE	(mm) S	895	-	-
HEIGHT OVER CAB.	(mm) T	2795	-	-
HOUSE WIDTH	(mm) U	2440	-	-
CAB. HEIGHT ABOVE HOUSE	(mm) V	450	-	-
CAB. WIDTH	(mm) W	1190	-	-
TUMBLER DISTANCE	(mm) X	3035	-	-
TRACK LENGTH	(mm) Y	3755	-	-
UNDERCARRIAGE WIDTH	(mm) Z	2590	-	-
SHOE WIDTH	(mm) a	600	-	-
TRACK HEIGHT	(mm) b	728	-	-
CAR BODY CLEARANCE	(mm) c	410	-	-

DX140LCR

Two - Piece Boom (Articulated Boom)

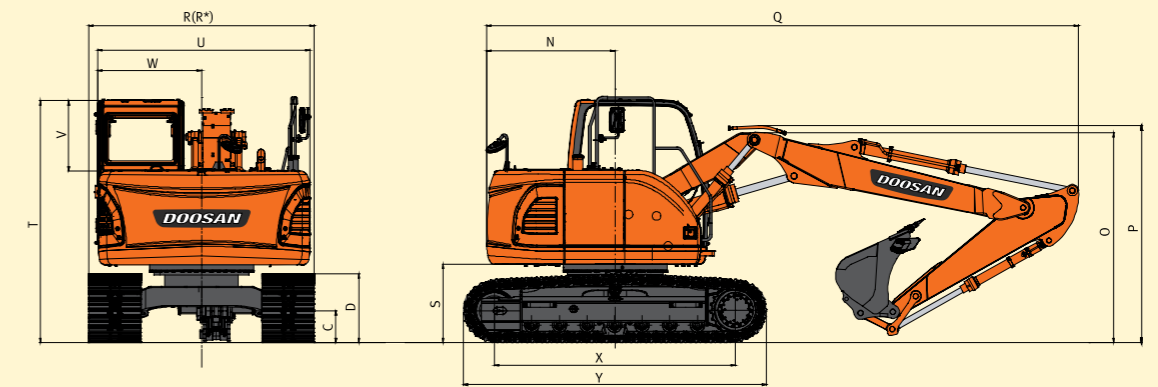

BOOM TYPE	(mm)	(TWO PIECE) 4980	
ARM TYPE	(mm)	2100	2500
BUCKET TYPE (SAE)	(m ³)	0.51	0.51
TAIL SWING RADIUS	(mm) N	1480	-
SHIPPING HEIGHT (BOOM)	(mm) O	2555	2680
SHIPPING HEIGHT (HOSE)	(mm) P	2655	2770
SHIPPING LENGTH	(mm) Q	7730	7700
SHIPPING WIDTH	(mm) R	2590	-
C/WEIGHT CLEARANCE	(mm) S	895	-
HEIGHT OVER CAB.	(mm) T	2795	-
HOUSE WIDTH	(mm) U	2440	-
CAB. HEIGHT ABOVE HOUSE	(mm) V	450	-
CAB. WIDTH	(mm) W	1190	-
TUMBLER DISTANCE	(mm) X	3035	-
TRACK LENGTH	(mm) Y	3755	-
UNDERCARRIAGE WIDTH	(mm) Z	2590	-
SHOE WIDTH	(mm) a	600	-
TRACK HEIGHT	(mm) b	728	-
CAR BODY CLEARANCE	(mm) c	410	-

Working Range

One - Piece Boom

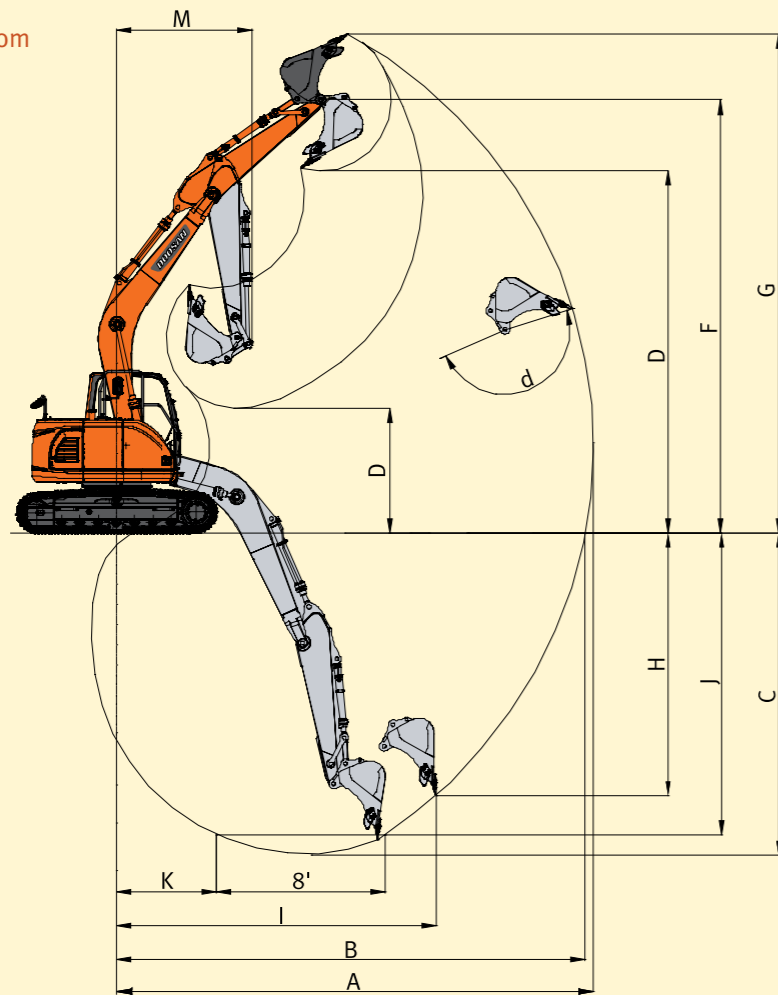

BOOM TYPE	(mm)	(ONE PIECE) 4600		
ARM TYPE	(mm)	2100	2500	3000
BUCKET TYPE (SAE)	(m ³)	0.51	0.51	0.39
MAX. DIGGING REACH	(mm) A	7845	8300	8680
MAX. DIGGING REACH (GROUND)	(mm) B	7690	8155	8540
MAX. DIGGING DEPTH	(mm) C	5100	5500	6000
MAX. LOADING HEIGHT	(mm) D	6390	6840	7055
MIN. LOADING HEIGHT	(mm) E	2895	2505	2085
MAX. DIGGING HEIGHT	(mm) F	8800	9280	9470
MAX. BUCKET PIN HEIGHT	(mm) G	7695	8185	8370
MAX. VERTICAL WALL DEPTH	(mm) H	3810	4555	4735
MAX. RADIUS VERTICAL	(mm) I	5690	5555	5925
MAX. DEPTH TO 8' LINE	(mm) J	4410	4900	5480
MIN. RADIUS 8' LINE	(mm) K	1360	1360	1360
MIN. DIGGING REACH	(mm) L	-52	350	850
MIN. SWING RADIUS	(mm) M	1885	1995	2290

Standard and Optional Equipment

DX140LCR

Standard Equipment

HYDRAULIC SYSTEM

- Boom and arm flow regeneration
- Boom and arm holding valves
- Swing anti-rebound valves
- Spare ports(valve)
- One-touch power boost

CABIN & INTERIOR

- Viscous cab mounts
- All weather sound suppressed type cab
- Air conditioner
- Adjustable suspension seat with head rest and adjustable arm rest
- Pull-up type front window and removable lower front window
- Room light
- Intermittent windshield wiper
- Cigarette lighter and ashtray
- Cup holder
- Hot & Cool box
- 7" Wide LCD color monitor panel
- Engine speed(RPM) control dial
- AM/FM radio
- Remote radio ON/OFF switch
- 12V spare powers socket
- Serial communication port for laptop PC interface
- Joystick lever with 3 switches
- Sunvisor
- Sun roof
- Wiper

SAFETY

- Large handrails and step
- Punched metal anti-slip plates
- Seat belt
- Hydraulic safety lock lever
- Safety glass
- Hammer for emergency escape
- Right and left rearview mirrors
- Travel alarm
- Emergency engine stop

UNDERCARRIAGE

- Hydraulic track adjuster
- Track guards
- Greased and sealed track link

OTHERS

- Double element air cleaner
- Fuel pre-filter
- Dust screen for radiator/oil cooler
- Engine overheat prevention system
- Engine restart prevention system
- Self-diagnostic system
- Alternator(24V, 60 amps)
- Electric horn
- Halogen working lights(frame mounted 2, boom mounted 2)

Optional Equipment

Some of the optional equipment may be standard in some markets. Some of the optional equipment will not be available in some markets. You must check with the local DOOSAN dealer about the availability or to release the adaptation following the needs of the applications.

SAFETY

- Boom and arm hose rupture protection valve
- Overload warning device
- Cabin Top/Front guard(ISO 10262, FOGS standard)
- Travel & swing alarm
- Rotation beacon
- Lamp on counter weight
- 3,500kg counter weight

CABIN & INTERIOR

- Air suspension seat
- MP3/CD player or cassette player
- Rain shield
- 2 front lamps
- 4 front + 2 rear lamps

UNDERCARRIAGE

- 500mm/600mm/700mm shoe
- 2,490mm/2,590mm/2,690mm dozer blade
- Rubber pad Track 500mm

OTHERS

- Piping for crusher
- Piping for quick clamp
- Breaker filter
- Fuel heater
- Fuel filler pump
- Rear viewer Camera

Lifting Capacity

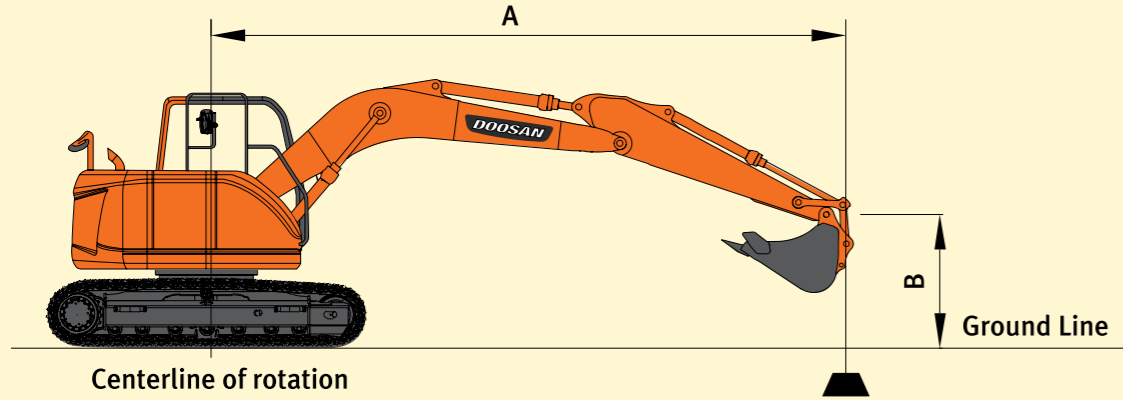

Standard

Boom : 4,600mm(15'1") Arm : 2,500mm(8'2") Bucket : SAE 0.51m³ (CECE 0.45 m³) Shoe : 600mm(24")

Metric

Unit : 1,000kg

A(m) B(m)	2		3		4		5		6		Max. Reach		A(m)
	Front	Side	Front	Side	Front	Side	Front	Side	Front	Side	Front	Side	
7					* 2.51	* 2.51					* 1.73	* 1.73	4.37
6					* 3.11	* 3.11	* 2.47	* 2.47			* 1.49	* 1.49	5.42
5					* 3.33	* 3.33	* 3.17	2.66	* 1.85	1.82	* 1.39	* 1.39	6.13
4			* 3.94	* 3.94	* 4.03	3.92	* 3.69	2.61	2.79	1.82	* 1.36	* 1.36	6.61
3			* 6.38	6.15	* 4.91	3.73	3.82	2.52	2.75	1.78	* 1.39	1.31	6.91
2			* 8.35	5.62	5.44	3.51	3.7	2.41	2.68	1.73	* 1.47	1.23	7.05
1			* 7.20	5.24	5.22	3.31	3.58	2.3	2.62	1.67	* 1.59	1.21	7.04
0			* 7.38	5.09	5.08	3.19	3.49	2.22	2.57	1.62	* 1.80	1.25	6.89
-1	* 5.38	* 5.38	8.54	5.06	5.02	3.13	3.45	2.18	2.55	1.6	* 2.11	1.35	6.58
-2	* 7.68	* 7.68	8.59	5.1	5.02	3.13	3.44	2.17	2.56	1.61	2.5	1.57	6.09
-3	* 10.60	* 10.60	* 7.78	5.2	5.08	3.19	3.49	2.22			3.12	1.99	5.37
-4			* 5.75	5.39	* 4.15	3.33					* 3.59	2.99	4.29

Feet

Unit : 1,000lb

A(ft) B(ft)	10		15		20		Max. Reach		A(ft)
	Front	Side	Front	Side	Front	Side	Front	Side	
25	* 6.06	* 6.06					* 4.57	* 4.57	11.13
20			* 6.25	* 6.25			* 3.32	* 3.32	17.50
15	* 7.29	* 7.29	* 7.75	6.91	* 4.91	3.89	* 3.02	* 3.02	20.86
10	* 13.65	13.23	* 9.69	6.54	5.88	3.81	* 3.06	2.89	22.62
5	19.17	11.62	9.35	6.04	5.69	3.63	* 3.35	2.67	23.18
0	* 16.99	10.92	8.94	5.67	5.52	3.47	* 3.96	2.74	22.62
-5	18.27	10.87	8.8	5.54	5.47	3.43	5.11	3.19	20.84
-10	* 16.75	11.17	8.93	5.66			6.98	4.45	17.47

1. RATINGS ARE BASED ON SAE J1097
2. LOAD POINT IS THE HOOK ON THE BACK OF THE BUCKET.
3. * RATED LOADS ARE BASED ON HYDRAULIC CAPACITY.
4. RATED LOADS DO NOT EXCEED 87% OF HYD. CAPACITY OR 75% OF TIPPING CAPACITY.

: Rating Over Front
 : Rating Over Side or 360 degree

DX140LCR

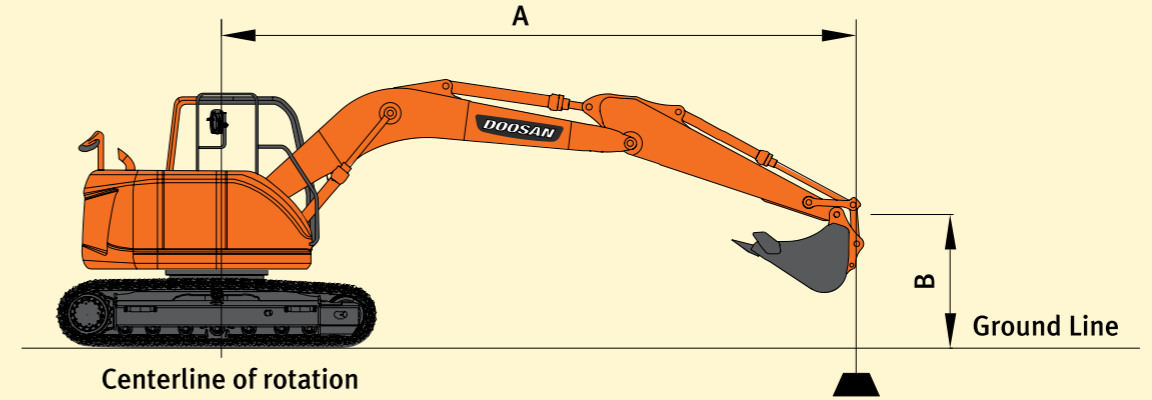

Option

Boom : 4,600mm(15'1") Arm : 3,000mm(9'10") Bucket : SAE 0.39m³ (CECE 0.34 m³) Shoe : 600mm(24")

Metric

Unit : 1,000kg

A(m) B(m)	2		3		4		5		6		7		Max. Reach		A(m)
	Front	Side	Front	Side	Front	Side	Front	Side	Front	Side	Front	Side	Front	Side	
7									* 1.73	* 1.73			* 1.51	* 1.51	5.18
6									* 2.31	* 2.31	* 1.52	* 1.52	* 1.39	* 1.39	6.09
5									* 2.57	* 2.57	* 2.19	* 2.19	* 1.34	* 1.34	6.73
4							* 2.90	* 2.90	* 2.92	* 2.92	* 2.61	* 2.61	* 1.65	* 1.65	7.17
3					* 4.00	* 4.00	* 3.88	* 3.88	* 3.60	* 3.60	* 3.11	2.87	* 2.17	* 2.17	7.44
2					* 6.65	* 6.65	* 5.05	* 5.05	* 4.23	3.73	* 3.74	2.77	* 2.59	2.14	7.58
1					* 8.49	8.3	* 6.04	5.1	* 4.81	3.57	* 4.09	2.67	* 2.93	2.08	7.57
0	* 4.72	* 4.72	* 9.55	7.92	* 6.76	4.88	* 5.27	3.44	* 4.37	2.59	* 3.06	2.03	* 1.76	* 1.76	7.43
-1	* 5.71	* 5.71	* 9.76	7.75	* 7.13	4.75	* 5.54	3.35	* 4.52	2.54	* 2.63	2	* 2.05	1.94	7.15
-2	* 7.04	* 7.04	* 9.67	7.71	* 7.12	4.69	* 5.55	3.31	* 4.48	2.51			* 2.53	2.14	6.70
-3	* 8.71	* 8.71	* 8.97	7.75	* 6.71	4.7	* 5.24	3.31	* 3.80	2.53			* 3.44	2.5	6.05
-4	* 10.82	* 10.82	* 7.67	* 7.67	* 5.80	4.78	* 4.39	3.38					* 4.23	3.26	5.12

Feet

Unit : 1,000lb

A(ft) B(ft)	10		15		20		Max. Reach		A(ft)
	Front	Side	Front	Side	Front	Side	Front	Side	
25							* 3.64	* 3.64	14.50
20			* 5.32	FALSE			* 3.07	* 3.07	19.77
15			* 5.99	FALSE	* 5.11	FALSE	* 2.94	* 2.94	22.76
10	* 8.52	FALSE	* 8.12	FALSE	* 6.66	6.16	* 3.03	* 3.03	24.39
5	* 16.44	FALSE	* 10.76	9.3	* 8.52	5.85	* 3.32	* 3.32	24.90
0	* 20.66	16.98	* 12.81	8.71	* 9.49	5.58	* 3.89	* 3.89	24.38
-5	* 21.32	16.52	* 13.60	8.4	* 9.81	5.42	* 5.01	4.47	22.75
-10	* 19.37	16.6	* 12.74	8.39			* 7.73	5.57	19.72
-15	* 14.23	-					* 9.49	9.24	14.43

1. RATINGS ARE BASED ON SAE J1097
2. LOAD POINT IS THE HOOK ON THE BACK OF THE BUCKET.
3. * RATED LOADS ARE BASED ON HYDRAULIC CAPACITY.
4. RATED LOADS DO NOT EXCEED 87% OF HYD. CAPACITY OR 75% OF TIPPING CAPACITY.

: Rating Over Front
 : Rating Over Side or 360 degree



Portable Power

DOOSAN



Doosan worldwide factories

- Heavy Equipment Factory
- Compact Equipment Factory
- Attachment Factory



Doosan Infracore Korea Office (HQ)
 27/F, Doosan Tower 18-12, Euljiro-6Ga, Jung-Gu
 Seoul 100-730 Korea
 Tel : 82 2 3398 8114

www.doosaninfracore.com/ce/