

ELECTRIC POWERED FORKLIFT

1.5 to 3.0 TON

8FB

SERIES



 **TOYOTA**

**EXPERIENCE TOYOTA'S LATEST
TECHNOLOGY AND RELIABILITY**

8FB SERIES

**ELECTRIC POWERED FORKLIFT
1.5 to 3.0 TON**

ADVANCED
SAFETY

MANAGEMENT
SUPPORT

OUTSTANDING
OPERABILITY

HIGH
PRODUCTIVITY
AND
EFFICIENCY

TOYOTA
25

ADVANCED SAFETY

Equipped with safety and stability features such as a High-mounted Rear Axle, SAS-ε and LED Blue Lights, the 8FB Series provides you with stable and smooth operations.

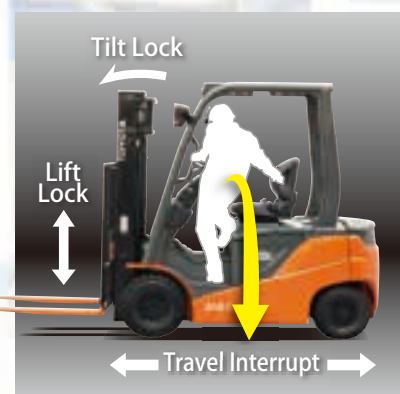

Limits unintended operations when the operator is away from the seat.
Operator Presence Sensing System



Switches off all power sources in the event of an emergency.
Emergency Power Shutdown Button

Reduces the risk of load spills due to unintended operations.

NEW Clamp Release Interlock for Attachments **OPT**

Note: The clamp-release button is located on the lever.



Features and equipment may vary depending on market.

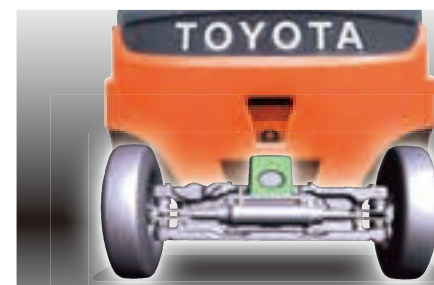

Reliable stability during turns.
High-mounted Rear Axle



OPT

ACTIVELY FUNCTIONS TO ACHIEVE EXCELLENT STABILITY

Prevents load spills by controlling tilt angle and tilt speed according to the height of the lift.

- Active Mast Front-tilt Angle Control
- Active Mast Tilt Speed Control

Controls turn speed and limits maximum traveling speed, according to the status of the vehicle.

- Automatic Vehicle-speed Control
- Automatic Turn-speed Control

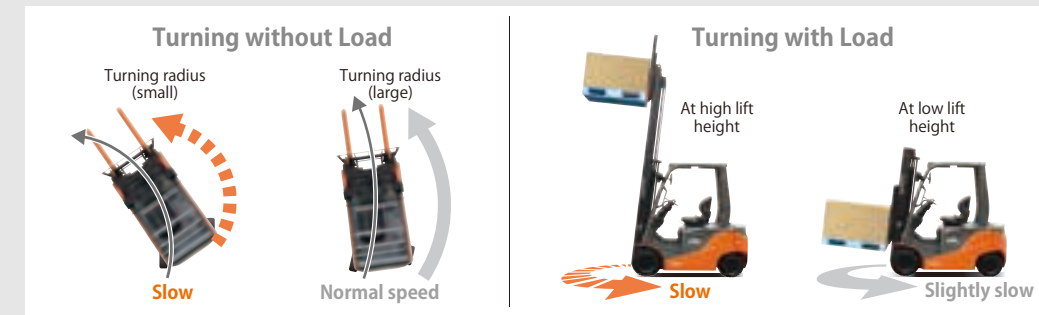

Supports smooth and accurate operations through operator-friendly load-handling and traveling controls.

- Automatic Fork-leveling Control
- Active Steering Synchronizer

Adds a visual alert of the forklift's presence.

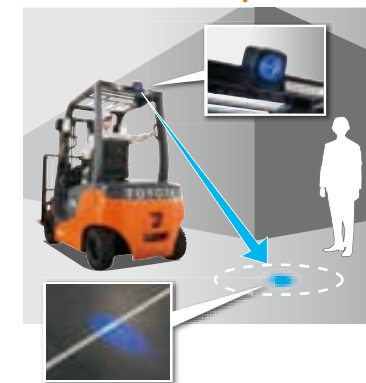

NEW LED Blue Light **OPT**

Brighter and more durable, with low energy consumption.



LED Headlights **OPT**

NEW LED Rear Combination Lights
NEW LED Rear Working Light **OPT**
LED Yellow Beacon **OPT**

MANAGEMENT SUPPORT

Achieves a more-secure and disciplined work environment through customized features to manage your forklifts and operators.



Easy to determine whether your operator's seat belt is properly fastened.

NEW Orange Seat Belt **OPT**

NEW Seat Belt Interlock System **OPT**

Note: When this option is selected, the color of the seat belt will be orange.



Warns by visual indicator and sounds if impact is detected.

Shock Sensor **OPT**

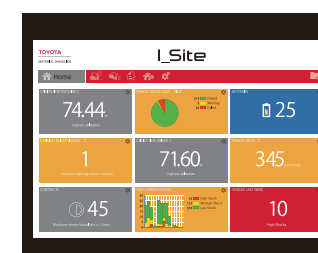

Visualizes a wide range of data such as vehicle operations by each operator, detected shocks and battery usage.

NEW I_Site **OPT**
(Telematics with POC)



Prevents use by unauthorized persons, and allows customized vehicle settings.

PIN*-code Entry System **OPT**
*Personal Identification Number

High-visibility display enabling a variety of vehicle settings as well as showing necessary information on the vehicle.

Standard Display



- Overheat warning indicator
- Power-select function indicator
- Parking brake warning indicator
- Hour meter
- and more

Multifunction Display **OPT**



- Digital speedmeter
- Wheel indicator
- Load weight indicator *
- and more

*Available on Deluxe Multifunction Display **OPT**

Display Screens

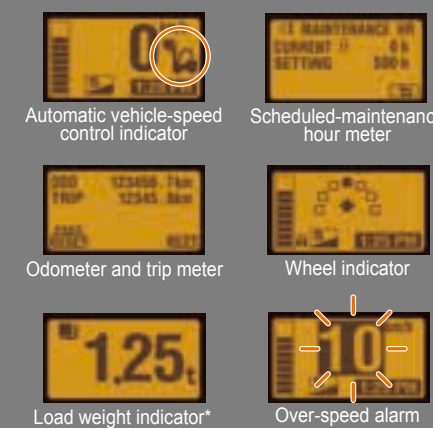

Automatic vehicle-speed control indicator

Scheduled-maintenance hour meter

Odometer and trip meter

Wheel indicator

Load weight indicator*

Over-speed alarm

Enables an operator to handle loads, or switch directions without even taking the hands off the steering wheel. Effortless, fingertip controls reduce fatigue and ensure a comfortable posture.



Mini Lever OPT / Joystick OPT

OUTSTANDING OPERABILITY

Great comfort to get more work done with less effort by the operator.

Small-diameter Steering Wheel **3**

Large Assist Grip **1**

Self-stowing Parking Brake **2**

LED Rear Combination Lights NEW

Rear Pillar Assist Grip OPT

ORS Seat with Suspension OPT

Wide Step **1**



Features and equipment may vary depending on market.

Makes everyday work stress-free with easy entry and exit.



1 Large Assist Grip / Wide Step

2 Self-stowing Parking Brake

Comfortable features to help you get through long working times.



3 Small-diameter Steering Wheel

4 ORS* Seat with Suspension OPT
*ORS: Operator Restraint System

Stops and then descends at a constant speed when the accelerator is released on slopes.



Anti-rollback

Enables outdoor operations in all weather.



High Water Resistance (Equivalent to IPX4)



Features and equipment may vary depending on market.

HIGH PRODUCTIVITY AND EFFICIENCY

Long operating times and assisting features for even more productive operations.

Quick and easy battery exchange for even more efficient work.



Battery Side-out **OPT**

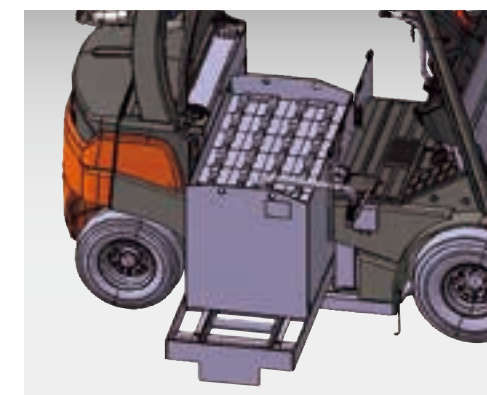

Battery Roll-out **OPT**

Positions your lift height with a single touch of the button.

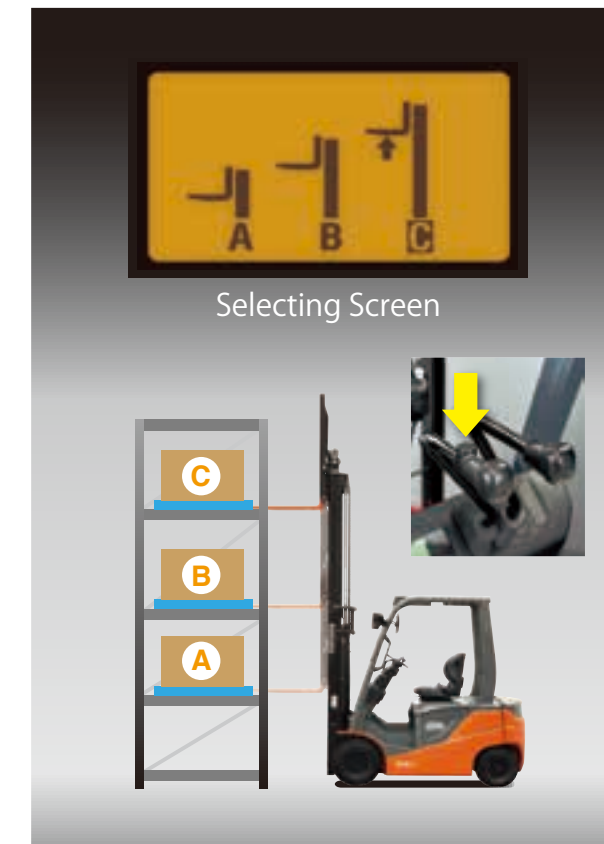

Height Selector **OPT**

Realizes long operating times with efficient energy recovery.

- Auto Power-off Function
- Regenerative Systems

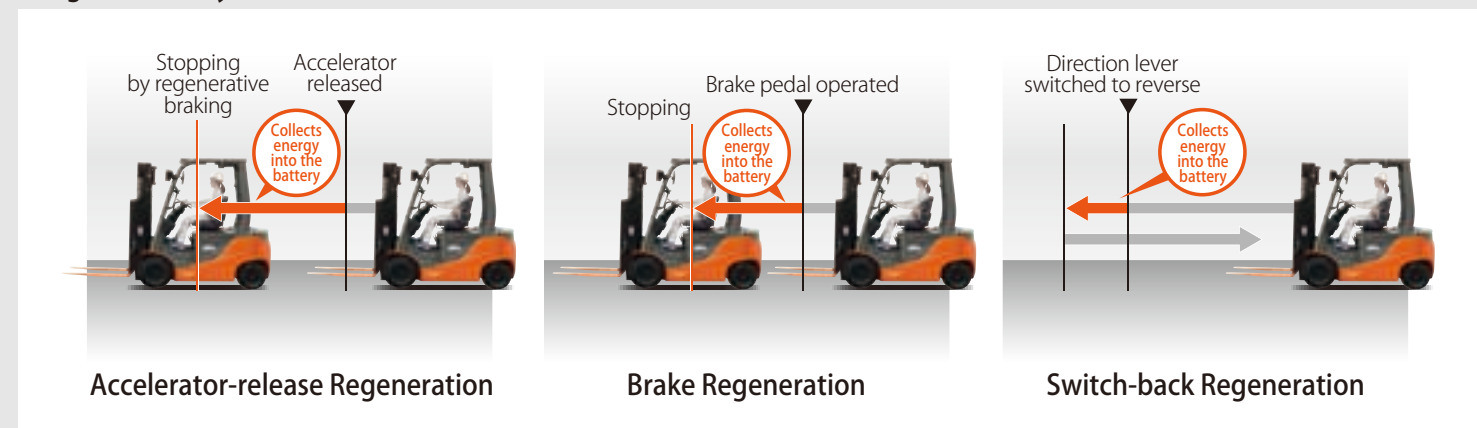

S mode achieves both long operating times and comfortable operations. H mode is also available for demanding operations.

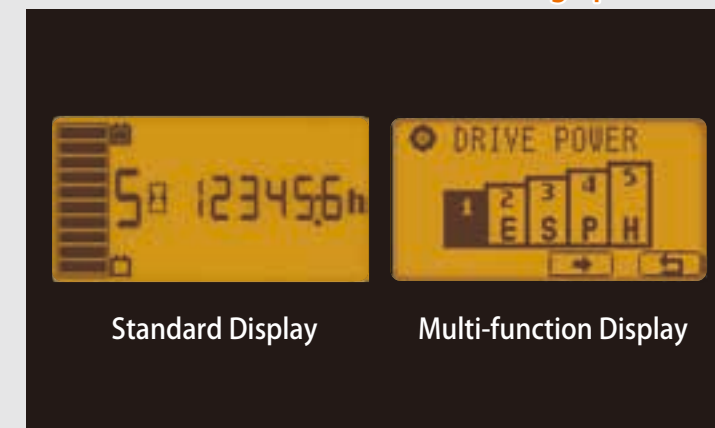

Power Select Function

For operators who want more travelling power only on slopes without adjusting power mode through multi-function display.



NEW Slope Sensing Auto Power Mode Selector **OPT**

MAIN SPECIFICATIONS

Model		8FBN15	8FBN18	8FBN20	8FBN25	8FBN30
Load Capacity	kg	1500	1750	2000	2500	3000
Load Center	mm	500	500	500	500	500
Overall Width	A mm	1060	1065	1180	1180	1235
Turning Radius (outside)	B mm	1770	1780	1980	2000	2210
Overhead Guard Height	C mm	2085	2095	2085	2085	2255
Length to Fork Face	D mm	2080	2115	2250	2325	2485

BATTERY AND MOTOR SPECIFICATIONS

Model			8FBN15	8FBN18	8FBN20	8FBN25	8FBN30
Voltage/Capacity (5-hour ratings)	Min.	V/Ah	48/390	48/390	48/470	48/565	80/370
	Max.	V/Ah	48/565	48/565	48/725	48/725	80/480
Electric Motors	Drive	kW	7.6	7.6	10.7	10.7	11.9
	Load Handling	kW	9.5	9.5	12.2	12.2	14.4

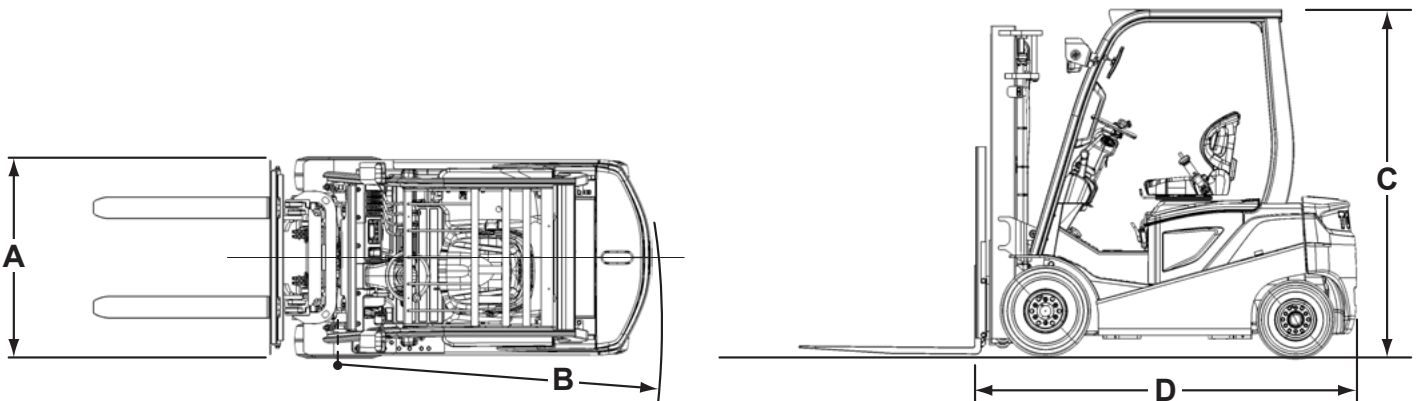

The data in this brochure was determined based on our standard testing condition. Operating performance may vary depending on the actual specifications and condition of the vehicle, as well as the conditions of the operating area.

Due to photography and printing, color of actual vehicle may vary from this brochure. Some photos have been computer-enhanced.

Photographs include optional equipment, and not all optional equipment is appropriate for all applications.

Availability and specifications are determined by market and are subject to change without notice.

Safe forklift operation is achieved by proper operator training and proper worksite rules. Please consult your Toyota representative regarding forklift selection and operator training.

Please consult your Toyota representative for details.

All rights reserved by Toyota Industries Corporation.