

SUMITOMO

SH470HD-6 SH490LHD-6 SH510LHD-6

SUMITOMO

- Engine Rated Power (Net): 270 kW·367 PS
- Operating Weight:
 - SH470HD-6 48,000~48,600 kg
 - SH490LHD-6 48,800~50,200 kg
 - SH510LHD-6 49,900~50,600 kg
 - SH490LHD-6 MASS 49,200~50,600 kg
 - SH510LHD-6 MASS 51,400~52,100 kg
- Bucket Capacity (ISO Heaped): 2.0~3.0 m³



 **SUMITOMO (S.H.I.)
CONSTRUCTION MACHINERY CO., LTD.**

731-1 Naganumahara-cho, Inage-ku, Chiba, 263-0001 Japan
For further information please contact: Phone : +81-43-420-1829 Facsimile : +81-43-420-1907

We are constantly improving our products and therefore reserve the right to change designs and specifications without notice.
Illustrations may include optional equipment and accessories and may not include all standard equipment.





Performance Refined. Evolution Defined.

Engine and Hydraulics 04-07

- New Generation Engine System "SPACE 5+"
- New Hydraulic System "SIH:S+"
- SUMITOMO Fuel Efficiency Technology
- Drastically Increased Productivity

Durability and Maintenance 08-11

- High Rigidity Attachments
- EMS
- Ground Level Maintenance

Safety and Operator Comfort 12-17

- Stylish and Spacious Cabin
- High-Definition Full Colour LCD Monitor
- FVM® (Field View Monitor) (option)

Specifications 18-23

ENGINEERED IN JAPAN

The world knows that Japanese designed and engineered products represent the highest quality, especially for Industrial Products. The hydraulic excavator is no exception when a totally integrated concept is required in design work involving key components, manufacturing engineering, and product quality assurance in the factory. SUMITOMO hydraulic excavators are designed and manufactured today to meet the global demands of our many customers with the concept of Performance, Reliability, and Fuel Efficiency foremost in our minds. This proven Japanese technology and quality gives SUMITOMO excavator customers total peace of mind and provide a complete solution for the demands of the construction industry.



**Performance Refined.
Evolution Defined.**



New Engine System **SPACE 5+ PLUS** + New Hydraulic System **SIHIS+ PLUS** = **13% Reduction in Fuel Consumption**
(as compared with DASH 5 [H mode])

New Generation Engine System "SPACE 5+"

The new engine system optimises fuel efficiency and environmental performance via the advanced common rail fuel injection system, cooled EGR system. At the same time, excellent response times are achieved.

Engine and Hydraulics



SH490LHD-6 has achieved a 13% fuel saving in comparison with our DASH 5 series, by fusing the new generation engine system "SPACE 5+" and the new hydraulic system "SIH:S+", further refining fuel efficiency. At the same time the newly developed ISUZU engine, contributes greatly to the environment.

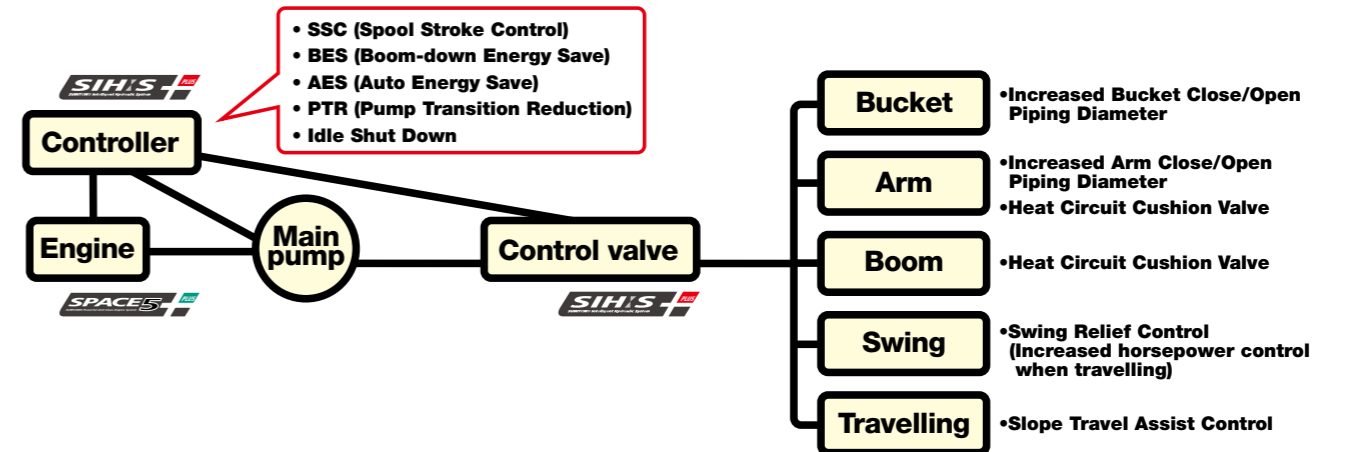

Mode Selection by Throttle **SUMITOMO UNIQUE DESIGN**

There are three working modes available:
SP (Super Power) for heavy duty applications,
H (Heavy) for normal working conditions,
A (Auto) for a wide range of operations.



Further Improvement of Fuel Consumption

The new technology has improved operations and reduced fuel consumption on each working mode.

- SP mode **9% Reduction in Fuel Consumption**
- H mode **13% Reduction in Fuel Consumption**
- A mode **9% Reduction in Fuel Consumption**
(as compared with DASH 5)

*Fuel consumption may vary from time to time depending on site and working conditions, operator skill and other circumstances.

ECO Gauge Showing Low Energy Operation

The energy saving conditions can be seen at a glance, as well as the fuel consumption indicator shown on the monitor.

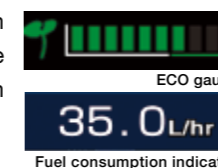

SUMITOMO Technology for Fuel Efficiency

- **SSC (Spool Stroke Control)** **SUMITOMO UNIQUE DESIGN**
Reduces engine load upon heavy duty operation.
- **BES (Boom-down Energy Save)** **SUMITOMO UNIQUE DESIGN**
Lowers engine speed upon boom-down and swing operation which does not require large oil flow.
- **AES (Auto Energy Save)** **SUMITOMO UNIQUE DESIGN**
Lowers engine speed accordingly when low engine load is sensed.
- **PTR (Pump Transition Reduction)**
Decreases engine load when the pump flow requirement is reduced upon abrupt pump load.
- **Idle Shut Down & Auto Idle**
Upon activation, idle shut down automatically shuts the engine down when the machine is not in operation for set amount of time. Auto Idle is also available, which makes the engine begin idling approximately five seconds after the operation levers are in neutral position.





**Performance Refined.
Evolution Defined.**

Engine and Hydraulics



SUMITOMO's original technology Spool Stroke Control (SSC), perfectly matches the engine and hydraulic power, and further improves the operational speed whilst maintaining smooth control of the machine.

Work Efficiency Drastically Increased SUMITOMO UNIQUE DESIGN

Spool Stroke Control (SSC) variably controls spool port flow rate, depending on the condition of operation. Improved power, speed, and smoother controls mean that work efficiency is dramatically increased.

9% Faster Cycle Time (SP mode)

Speed increase by 9% in cycle time has been achieved, giving further advance in productivity (as compared with DASH 5 [SP mode]).

Real Digging Power

The true digging force can not be expressed by a maximum digging power figure listed in sales brochures. With an improved hydraulic system and with a large arm cylinder, the arm-in motion speed slowdown is minimised. The digging power when combined with the attachment speed in motion convert to the operator's "Real Digging Power".

Automatic Power Boost

The digging power increases automatically in quick response to the working conditions during heavy-duty digging work. This is a design unique to SUMITOMO, and continues for eight seconds (SP/H mode).

Speed and Power, Increases Productivity Drastically

- SP mode

9% faster cycle time
- H mode

7% faster cycle time
- A mode

7% faster cycle time
(as compared with DASH 5)

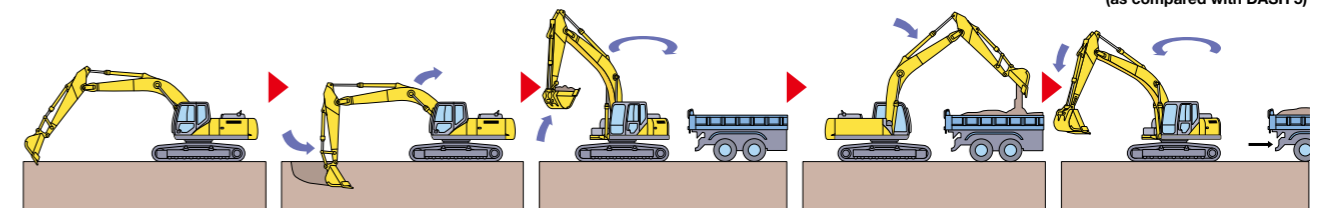

*Based on SUMITOMO's testing condition and results.

Operating Condition Easily Viewable on Display

Various control such as working modes and auxiliary hydraulic setting can be easily selected by the universally designed switch panel, and what's being selected can be easily viewed on the 7" wide monitor.





Durability

High Rigidity Attachments

The structure of the boom and arm has been further improved, ensuring strength and durability. In addition, high strength castings are used for the boom base and arm end, improving reliability.

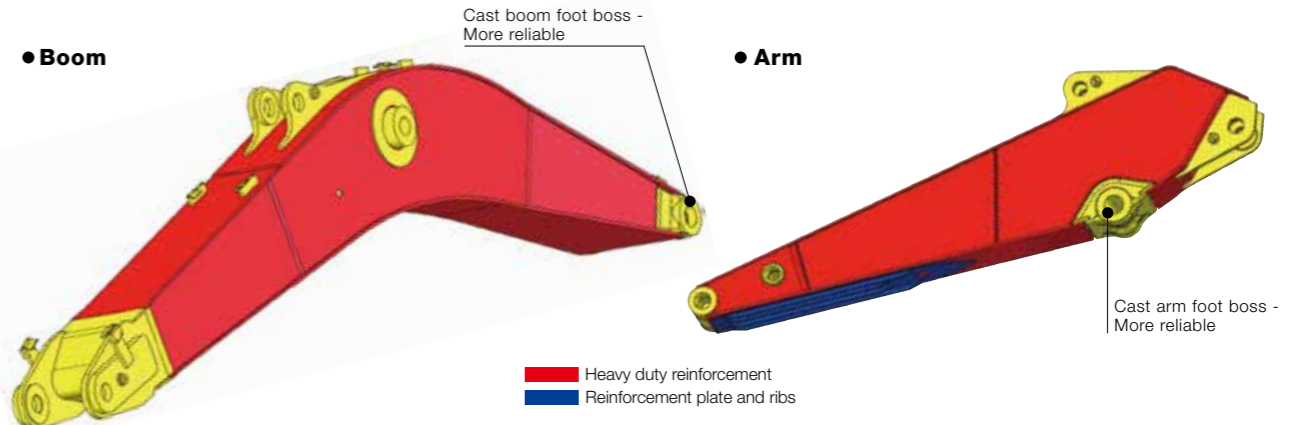

EMS (Easy Maintenance System) as Standard

SUMITOMO's EMS keeps the pins and bushes fully lubricated at all times and prevents rattling. This system significantly extends the service life of the pins and bushes.

The lubrication interval is 1,000 hours, keeping the joints lubricated for a long time and extending the service life of parts by reducing abrasion and rattling.

● Greasing interval: **1,000 hours**
* The greasing interval depends on the working conditions.

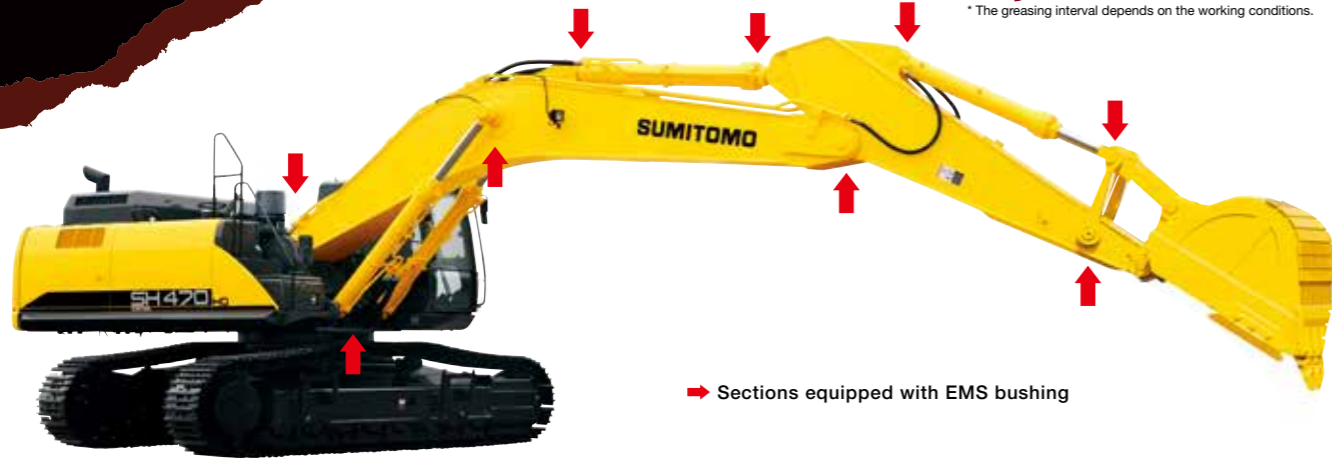

→ Sections equipped with EMS bushing

EMS bushing

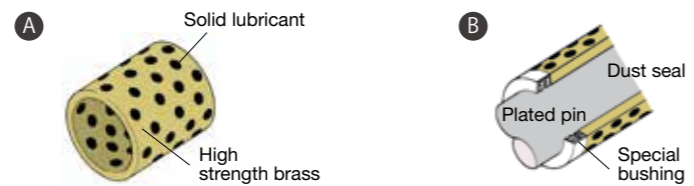

A A solid lubricant embedded in high strength brass forms a layer on the bushing surface to prevent contact between metals, maintaining an excellent lubricated state to reduce abrasion of joints.

B The surface of the pin is plated to increase the surface hardness and improve the wear resistance accordingly.

High Rigidity Swing Frame

The swing frame has been strengthened to support the new cabin, as well as to increase durability.

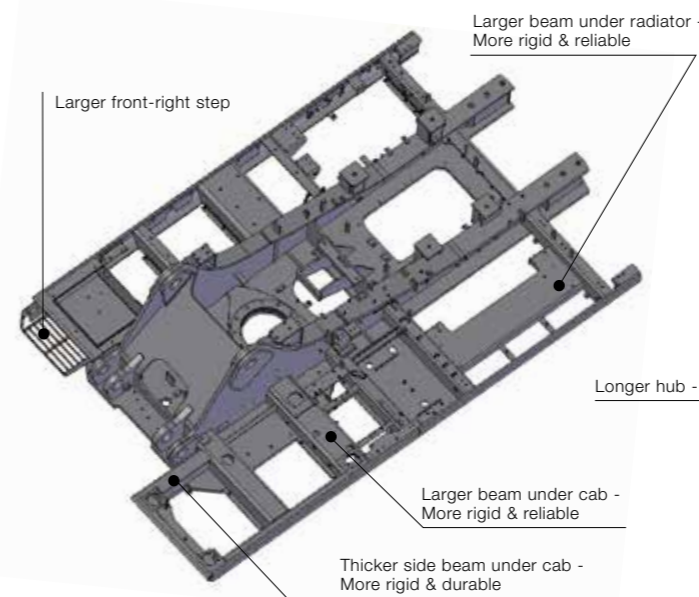

High Rigidity Undercarriage

For improved mobility, the track system has been strengthened ensuring longer wear life, performance, and improved reliability.

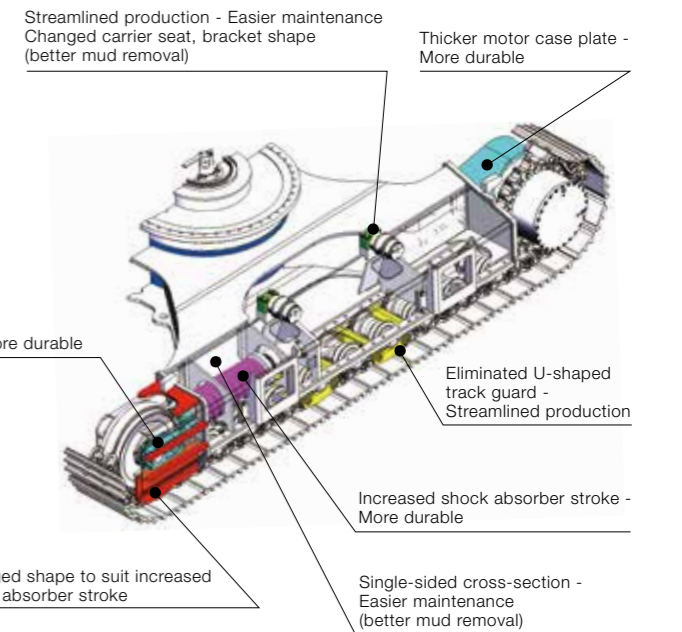

Precautionary use of EMS

- ① Grease is enclosed, however greasing is necessary every 1000 hours or six months depending on the level of dusting conditions.
- ② Greasing is also necessary after any components have been submerged underwater for prolonged periods.
- ③ Greasing is also recommended after use with hydraulic breakers, crushers or other high impact attachments such as Rock Saws etc.
- ④ Bucket pins should be cleaned thoroughly when removing or attaching new buckets.



**Performance Refined.
Evolution Defined.**

Maintenance

Serviceability and durability are also important points of machine performance. Ground level access to the engine area makes daily maintenance extremely straightforward. Reliability has been further enhanced by increasing cooling capability and durability.

Ground Level Access to Engine Area Improves Preventative Maintenance

Parts cleaning and maintenance are possible from the ground without climbing onto the upper structure of the excavator body.

• Increased Cooling Capability

With the larger radiator and oil cooler, cooling capacity is increased, thus improving reliability. In addition, cleaning of the dust-proof net is simplified.

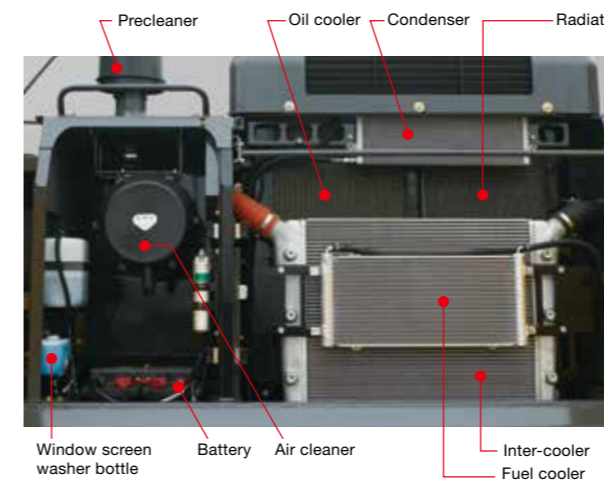

High-Performance Return Filter

The hydraulic oil change interval is 5,000 hours, and the return filter change interval is 2,000 hours. One high performance return filter keeps the same level of filtering as a nephron.



• Hydraulic oil change: **5,000** hours

• Life of filter: **2,000** hours

* The oil and filter change interval varies by the working conditions.

Cab Floor Mat **SUMITOMO** UNIQUE DESIGN

The washable floor mat has been redesigned for ease of removing and cleaning.



• Easy Filter Replacement

A fuel prefilter to the main fuel filter is provided as standard equipment to reduce trouble. In addition, the fuel and oil filters are installed at ground-accessible location to facilitate replacement.

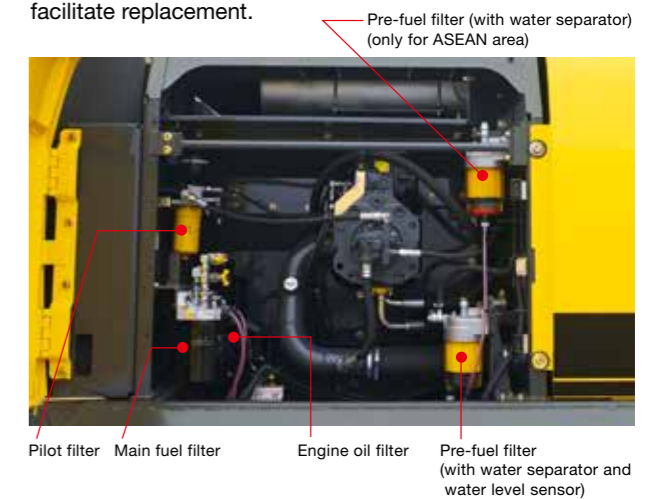

Pre-air cleaner

A pre air cleaner is provided as standard. The air cleaner cleaning frequency is minimised, even when operating in dusty conditions.



Easy Access to A/C Filter

The air intake filter is located in a lockable compartment to make it easier to replace, and access to the inside cab filter has been simplified.



Fuse Box Location

The fuse box has been located in a separate compartment behind the seat, allowing easier access.



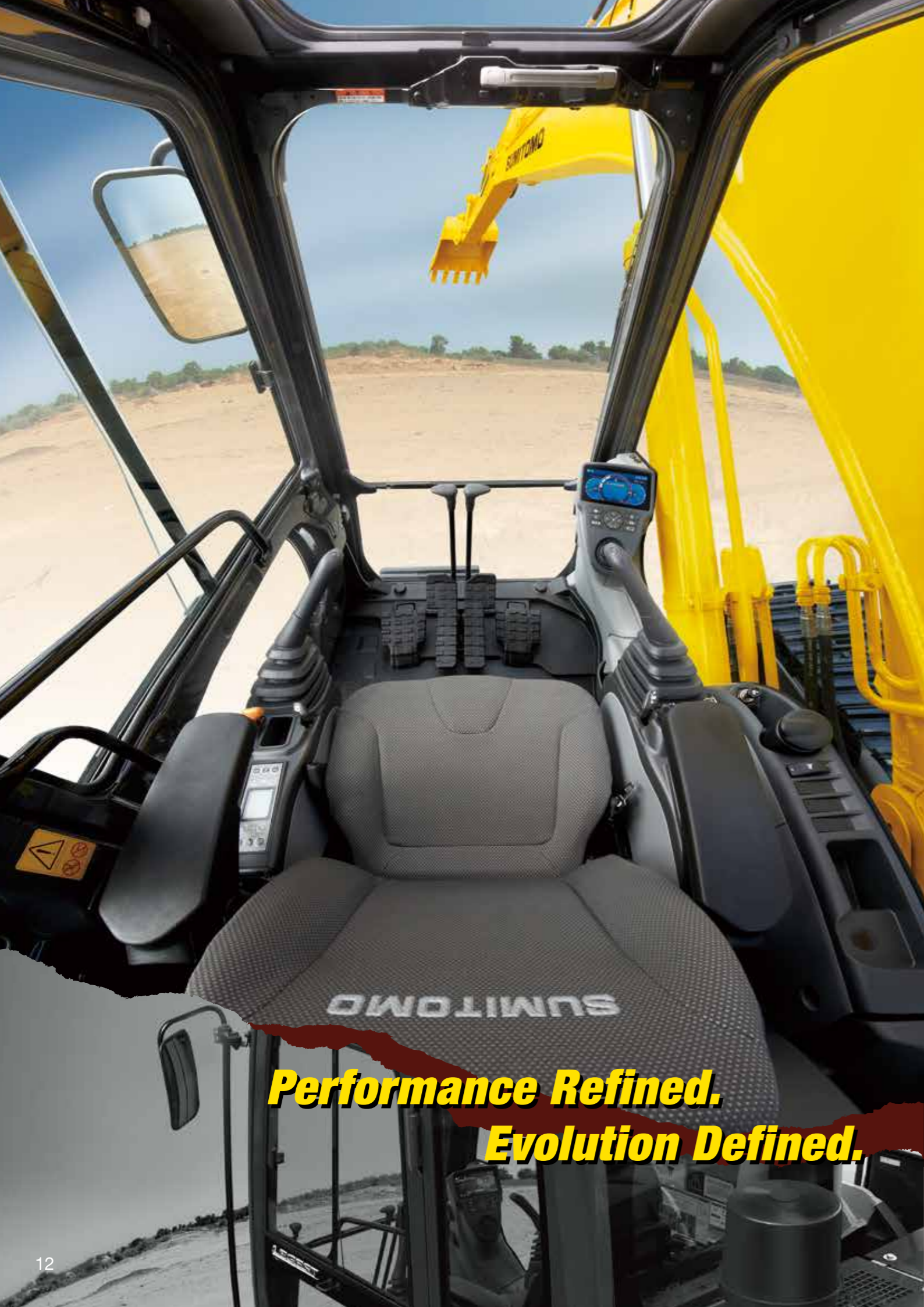

**Performance Refined.
Evolution Defined.**

Safety and Operator Comfort

A new strengthened safety cabin has been provided. The reinforced cabin greatly increases operator's safety.

Newly Designed Safety Cabin

The optimised design and strengthened parts increase the overall cabin strength.

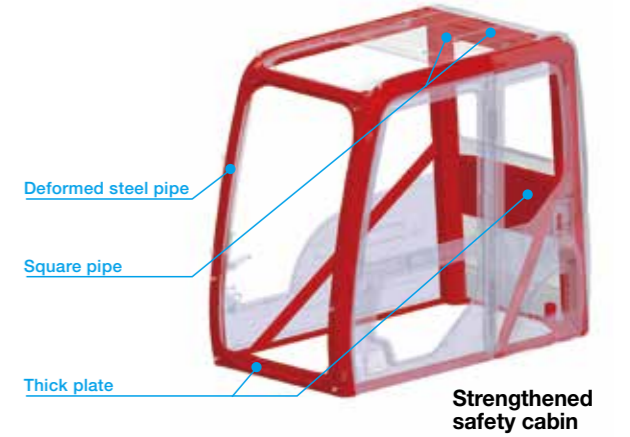

Wide View Increases Safety of Work

In addition to the wide front view, the upper view has been widened to enhance work safety.



New Cab Suspension Mounts

The new cab suspension mounts reduce vibration and impact transmitted to the cabin, and improve the operator's sitting quality and reduce operator fatigue. The sealed and pressurised cabin prevents entry of dust from outside.

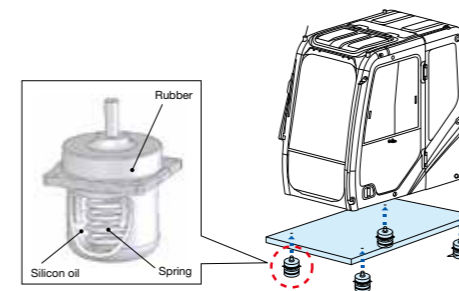

New FOPS Level 2 Head Guard (option)

FOPS Level 2 head guard is available as an option. The see-through grille has been redesigned for better protection and visibility.



Safe and Easy Entry into and Exit from the Cab

A large handrail for easy opening/closing of the door and increased floor space permit the operator to get in and out of the cab easily.



Easy Access to the Upper Structure



New larger front-right step

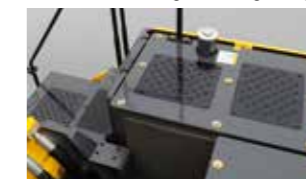

Non-slip plate



ISO-compliant large handrail

Cab Front Guard (option)

Optional cab front guard improves operator's safety from flying objects.



**Performance Refined.
Evolution Defined.**

Safety and Operator Comfort

The spacious cab on suspension mounts and reclining suspension seat softens operator fatigue and provide a relaxed environment.

Stylish and Spacious Cab

Wide cab space and floor space ensure more comfortable operation. In addition to the tilting console that is adjustable in four steps vertically, the increased sliding distance ensures optimum working conditions. Moreover, in cab noise level has been reduced (as compared with DASH 5).

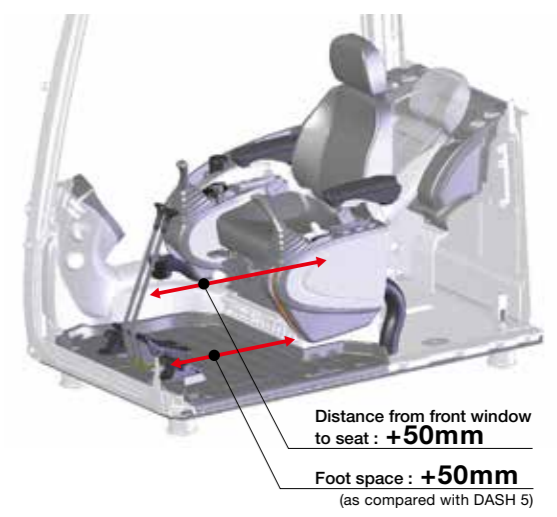

Super-comfortable Reclining Seat

The seat reclining system allows the operator to lay the seat flat and to rest on site without having to remove the headrest. The suspension seat eliminates vibration and fatigue. Air suspension is also available as option.

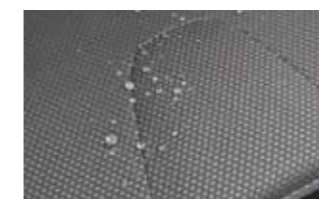

The highly water repellant seat covering is tough on dirt and water.



Air suspension (option)

Auxiliary Operation Pedal

The auxiliary operation pedal is lighter to depress and the pedal angle is adjustable.



Comfortable Equipment



Luggage space



Hot & cool box



Magazine rack

Automatic Air Conditioner

Fully automatic climate control is available through the eight vents, with an 8% stronger A/C unit, and a 24% improvement in airflow. (as compared with DASH 5)



Radio and Speaker with USB Port and MP3 Jack

In addition to the AM/FM radio and dual speaker system with improved sound quality, auxiliary audio port is provided standard for devices such as MP3 players.



Lever Switches

One-touch idle, horn, radio mute, or one-touch wiper buttons are installed on the operation levers in consideration of improved operability while working.



Radio mute switch (left lever)



One-touch wiper switch (right lever)



Safety and Operator Comfort

To support the operator in the field, the DASH 6 incorporates a 7" wide full-colour LCD monitor with numerous functions and easy operation switch panel. The cabin with enhanced operator comfort ensures a safe working environment.

Large High-Definition LCD Monitor

A new large high-definition full colour LCD monitor has been introduced with better visibility and a switch panel which is easy to operate. Added functionality such as ECO gauge showing parameter of energy saving, display of operation status and warning messages, provides accurate information which improves work efficiency and safety.

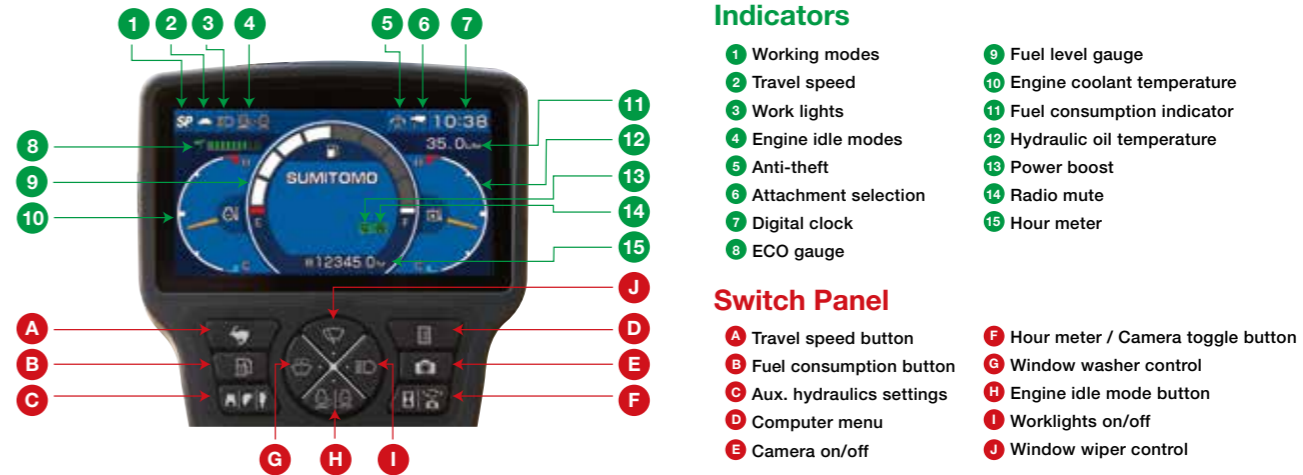

FVM for Greater Worksite Safety (option) SUMITOMO UNIQUE DESIGN

As an additional option, the monitor can be upgraded to Sumitomo's proprietary FVM (Field View Monitor), which provides a clear, top-down view of the excavator around to 270° during the day and at night. This makes it so much easier for the operator to monitor the area nearby, enhancing overall safety on worksites. Different camera views can also be toggled on a single monitor.



*The FVM is a support system for checking the safety of the surroundings; it does not prevent collisions with obstructions. Reliance on the FVM during operation should be avoided, and remember to work safely. *FVM is a registered trademark of Sumitomo Heavy Industries.

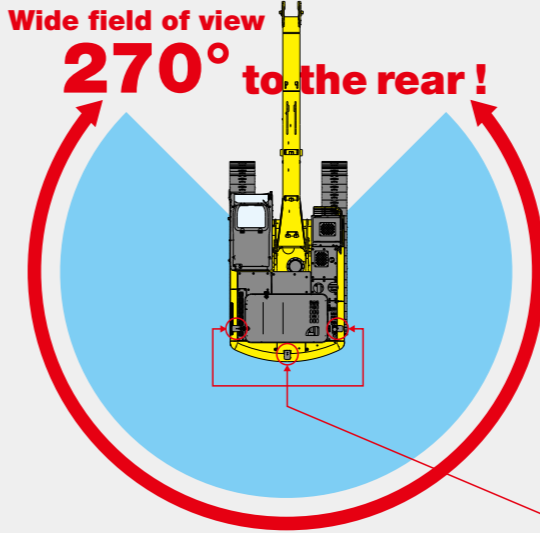

FVM screen (daytime)



FVM screen (night time)

Easy Switching

A single button is used to toggle the image through the top-down view and individual cameras (right side, rear). Safety checks can be made using the desired or appropriate view.



Rearview camera (option)



Side camera (option)

Working Range

	SH470HD-6/SH490LHD-6		
Arm length	2.53 m	3.13 m	3.38 m
Boom length	6.98 m		
A Max digging radius	11,250 mm	11,820 mm	12,020 mm
B Max digging depth	6,890 mm	7,500 mm	7,750 mm
C Max digging height	10,820 mm	11,140 mm	11,150 mm
D Max dumping height	7,400 mm	7,690 mm	7,720 mm
E Max vertical wall cut depth	4,840 mm	5,630 mm	5,710 mm
F Min front swing radius	5,140 mm	5,030 mm	4,990 mm
G Rear end swing radius	3,730 mm		

	SH510LHD-6		
Arm length	2.53 m	3.13 m	3.38 m
Boom length	6.98 m		
A Max digging radius	11,250 mm	11,820 mm	12,020 mm
B Max digging depth	6,740 mm	7,350 mm	7,600 mm
C Max digging height	10,970 mm	11,290 mm	11,300 mm
D Max dumping height	7,550 mm	7,840 mm	7,870 mm
E Max vertical wall cut depth	4,840 mm	5,630 mm	5,710 mm
F Min front swing radius	5,140 mm	5,030 mm	4,990 mm
G Rear end swing radius	3,730 mm		

	SH490LHD-6 MASS	SH510LHD-6 MASS
Arm length	2.53 m	2.53 m
Boom length	6.55 m	6.55 m
A Max digging radius	10,920 mm	10,920 mm
B Max digging depth	6,600 mm	6,450 mm
C Max digging height	10,560 mm	10,710 mm
D Max dumping height	7,080 mm	7,230 mm
E Max vertical wall cut depth	4,030 mm	3,880 mm
F Min front swing radius	4,800 mm	4,800 mm
G Rear end swing radius	3,730 mm	3,730 mm

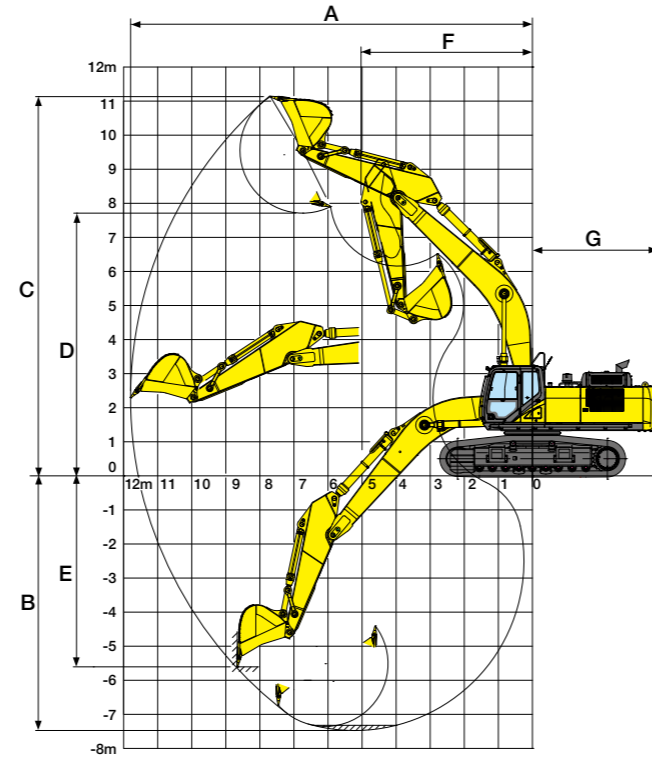

Principle Specifications

	SH470HD-6 STD Specifications	SH490LHD-6 STD Specifications	SH510LHD-6 STD Specifications	SH490LHD-6 MASS STD Specifications	SH510LHD-6 MASS STD Specifications	
Base	Boom length	6.98 m (HD type)			6.55 m (HD type)	
	Arm length	3.13 m (HD type)			2.53 m (HD type)	
	Bucket capacity (ISO heaped)	2.2 m ³ (Rock type)	2.4 m ³ (Rock type)		2.8 m ³ (Rock type)	
Engine	Std. operating weight	48,000 kg	48,800 kg	50,200 kg	49,200 kg	
	Make & model	ISUZU GH-6UZ1X				
	Rated output (SAE J1349)	270 kW/2,000 min ⁻¹				
	Displacement	9.839 ltr				
Hydraulic System	Main pump	2 variable displacement axial piston pumps with regulating system				
	Max pressure	31.4 MPa				
	/with auto power boost	34.3 MPa				
	Travel motor	Variable displacement axial piston motor				
Performance	Parking brake type	Mechanical disc brake				
	Swing motor	Fixed displacement axial piston motor				
	Travel speed	5.3 / 3.2 km/h				
	Drawbar pull	340 kN	339 kN	338 kN	339 kN	338 kN
Others	Gradeability	70% (<35°)				
	Ground pressure	89 kPa	84 kPa	86 kPa	84 kPa	88 kPa
	Swing speed	9.0 min ⁻¹				
	Bucket digging force (ISO 6015)	243 kN		274 kN		274 kN
Performance	/with auto power boost	266 kN		300 kN		300 kN
	Arm digging force	221 kN		251 kN		251 kN
	/with auto power boost	242 kN		274 kN		274 kN
	Fuel tank	650 ltr				
Hydraulic fluid tank	230 ltr					

Standard Equipment

[Hydraulic system]

- SIH:S+ hydraulic system
- Operation mode (SP, H and A mode)
- Automatic 2-speed travel
- Automatic power boost
- Arm/boom/bucket reactivation circuit
- Automatic swing parking system
- High-performance return filter
- Hydraulic drive cooling fan

[Cabin/interior equipment]

- Strengthened cabin
- Top guard OPG level1 (in cab structure)
- Shock-less cab suspension by 4-point fluid mounts
- Built-in type full-colour monitor display
- Tilting console
- Open air introducing pressurised full-automatic air conditioner
- Defroster
- Hot & cool box
- Water-resistant seat
- Seat suspension
- Armrest & headrest
- Windscreen wiper (with intermittent operation function)
- Cup holder
- AM/FM radio (with muting function) with AUX port & USB port
- Radio mute / Windscreen wiper one-touch control on joystick
- Clock
- Magazine rack
- Accessory case
- Floor mat
- Ashtray & cigarette lighter
- Cab light (Auto-OFF function)
- Coat hook

[Safety equipment]

- Rearview mirror (left/right)
- Emergency escape tool
- Retracting seat belt
- Gate lock lever
- Travel alarm (with on and off switch)
- Anti-theft alarm system
- Engine room firewall
- Fan guard
- Engine emergency stop switch
- Engine neutral start

[Others]

- Auto/one-touch idling
- Auto idle shutdown system
- EMS
- Long-life hydraulic oil
- Five lights (cab-top 2, boom 2, main unit 1)
- Fuel filter
- Fuel prefilter (with water separator)
- Double-element air cleaner
- Grease-enclosed track link
- Large tool box
- A set of tools
- Precleaner
- Grouped greasing for TTB

Accessories (option)

■ Rain deflector



■ Front guard (OPG level 1 or 2)



■ Front net guard (full/lower)



■ Head guard (FOPS level 2)



■ Side camera



■ Rear view camera



■ Full track guard

■ Refuel pump

■ ISO compliant mirror

■ Sun visor

■ Rain deflector

■ Polycarbonate roof top window with sunshade

■ ISO compliant guardrail

■ Hose burst check valve (HBCV) for boom/arm cylinders

■ Air suspension (KAB seat)

■ FVM (Field View Monitor)

■ 12V power (DC-DC converter)

Dimensions

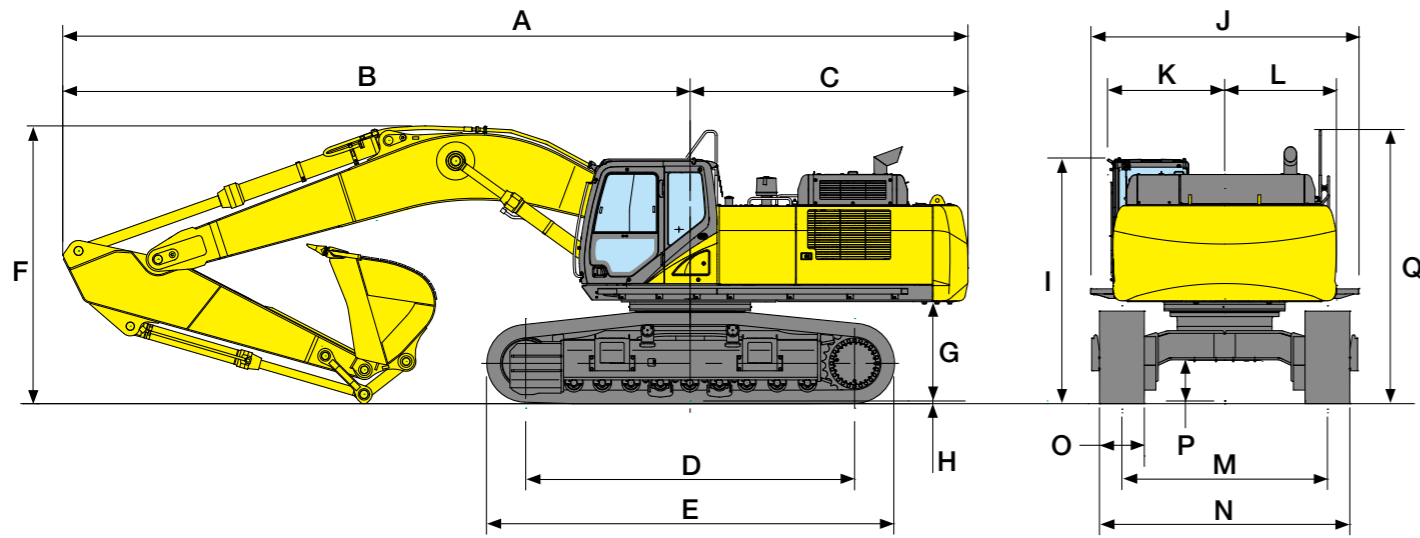

Model	SH470HD-6			SH490LHD-6		
Arm length	2.53 m	3.13 m	3.38 m	2.53 m	3.13 m	3.38 m
A Overall length	12,110 mm	12,110 mm	12,070 mm	12,110 mm	12,110 mm	12,070 mm
B Length from centre of machine (to arm top)	8,390 mm	8,390 mm	8,350 mm	8,390 mm	8,390 mm	8,350 mm
C Length from centre of machine (to rear end)		3,720 mm			3,720 mm	
D Centre to centre of wheels		4,050 mm			4,400 mm	
E Overall track length		5,100 mm			5,450 mm	
F Overall height	3,650 mm	3,720 mm	3,630 mm	3,650 mm	3,720 mm	3,630 mm
G Clearance height under upper structure		1,330 mm			1,330 mm	
H Shoe lug height		36 mm			36 mm	
I Cab height		3,290 mm			3,290 mm	
J Upper structure overall width (with cat walk*)		3,060 (3,590) mm			3,060 (3,590) mm	
K Width from centre of machine (left side)		1,570 mm			1,570 mm	
L Width from centre of machine (right side)		1,490 mm			1,490 mm	
M Track gauge		2,750 mm			2,750 mm	
N Overall width		3,560 mm			3,560 mm	
O Std. shoe width		600 mm			600 mm	
P Minimum ground clearance		535 mm			535 mm	
Q Overall height (to top of handrail)		3,660 mm			3,660 mm	

* with cat walk-option

Model	SH510LHD-6		SH490LHD-6 MASS	SH510LHD-6 MASS
Arm length	2.53 m	3.13 m	3.38 m	2.53 m
A Overall length	12,090 mm	12,100 mm	12,030 mm	11,680 mm
B Length from centre of machine (to arm top)	8,370 mm	8,380 mm	8,310 mm	7,960 mm
C Length from centre of machine (to rear end)		3,720 mm		3,720 mm
D Centre to centre of wheels		4,400 mm		4,400 mm
E Overall track length		5,450 mm		5,450 mm
F Overall height	3,720 mm	3,770 mm	3,670 mm	3,770 mm
G Clearance height under upper structure		1,480 mm		1,330 mm
H Shoe lug height		36 mm		36 mm
I Cab height		3,440 mm		3,290 mm
J Upper structure overall width (with cat walk*)		3,060 (3,590) mm		3,060 (3,590) mm
K Width from centre of machine (left side)		1,570 mm		1,570 mm
L Width from centre of machine (right side)		1,490 mm		1,490 mm
M Track gauge (retract)		2,890 (2,390) mm		2,750 mm
N Overall width (retract)		3,700 (3,200) mm		3,560 mm
O Std. shoe width		600 mm		600 mm
P Minimum ground clearance		720 mm		535 mm
Q Overall height (to top of handrail)		3,810 mm		3,660 mm

* with cat walk-option

● Boom

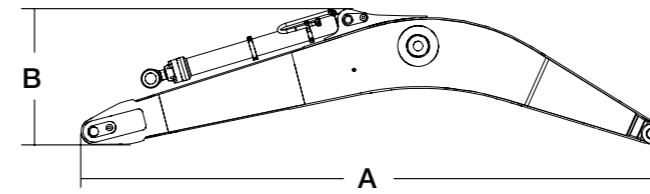

● Boom cylinder

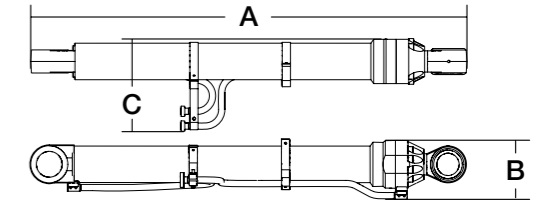

● Arm

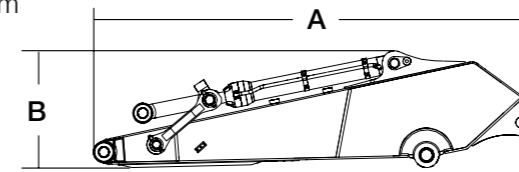

● Bucket

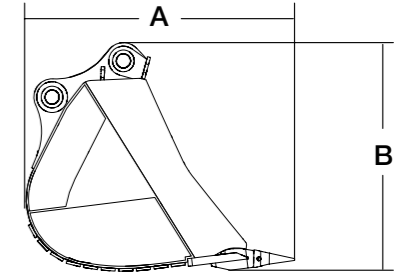

● Counterweight

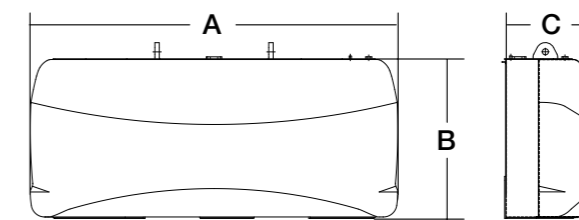

Boom

Model	SH470HD-6/SH490LHD-6/SH510LHD-6	
Type	6.55 m Boom	6.98 m Boom
A	6.85 m	7.28 m
B	1.86 m	1.79 m
Width	0.87 m	0.87 m
Weight	4,700 kg	4,700 kg

Boom cylinder

Model	SH470HD-6/SH490LHD-6/SH510LHD-6
A	2.33 m
B	0.32 m
C	0.5 m
Weight	1,000 kg (500 kg × 2)

Arm

Model	SH470HD-6/SH490LHD-6/SH510LHD-6			SH490LHD-6 MASS/SH510LHD-6 MASS
Type	2.53 m Arm	3.13 m Arm	3.38 m Arm	2.53 m Arm
A	3.82 m	4.40 m	4.63 m	3.82 m
B	1.30 m	1.23 m	1.23 m	1.30 m
Width	0.65 m	0.65 m	0.65 m	0.65 m
Weight	2,400 kg	2,600 kg	2,700 kg	2,600 kg

Bucket

Model	SH470HD-6/SH490LHD-6/SH510LHD-6					SH490LHD-6 MASS/SH510LHD-6 MASS	
Bucket capacity (ISO/SAE/PCSA heaped)	2.0 m ³	2.0 m ³	2.2 m ³	2.4 m ³	2.6 m ³	2.8 m ³	3.0 m ³
Type	HD	Rock	Rock	Rock	Rock	Rock	Rock
A	1.87 m	1.91 m			2.03 m		
B	1.53 m	1.63 m			1.67 m		
Width	With side cutter	1.64 m	-	-	-	-	-
	Without side cutter	-	1.57 m	1.64 m	1.76 m	1.87 m	1.94 m
Weight		1,930 kg	2,200 kg	2,280 kg	2,360 kg	2,520 kg	2,830 kg

Counterweight

Model	SH470HD-6/SH490LHD-6/SH510LHD-6
A	2.99 m
B	1.43 m
C	0.74 m
Weight	9,200 kg / 10,000 kg