

DOOSAN

Construction Equipment

DL420

Engine Power	SAE J1995, gross 209 kW (280 HP) @ 2,000 rpm
Operational Weight	22,300 kg (49,163 lb)
Bucket Capacity (SAE)	3.5 ~ 7.0 m ³ (4.6 ~ 9.2 yd ³)



THE NEW DL420 WHEEL LOADER HAS ALL THE ADVANTAGES

DL420

THE NEW DL420 WHEEL LOADER HAS ALL THE ADVANTAGES OF THE PREVIOUS MODEL, THE KEY PHRASE USED DURING THE DEVELOPMENT OF THE DL420 WAS "GIVING OPTIMUM VALUE TO THE END USER."

INCREASED PRODUCTION, thanks to the use of the Unit injection engine and the excellent synchronization of the drive train with the hydraulic system.

IMPROVED ERGONOMICS, increased comfort and excellent all round visibility ensuring safe and pleasant working conditions.

IMPROVED RELIABILITY, through the use of higher performance new materials, the development of new computer-assisted structural design techniques and by intensive and systematic test programs. All of these combine to increase the life of vital components and reduce operating costs.





PERFORMANCE & PRODUCTIVITY

DL420

Perfect integration of power and intelligence. When exceptional power is combined with the very best workmanship, the wheel loader reaches the peak of its performance. The DL420 loader gives you outstanding productivity. The reason is, on the one hand, the impressive digging power allows the hardest materials to be tackled and, and on the other, high tractive power enables easy penetration. With a powerful hydraulic system, the operator can work quickly and powerfully. At the heart of the loader is the Cummins QSM 11 electronic engine.



CUMMINS QSM 11 ENGINE

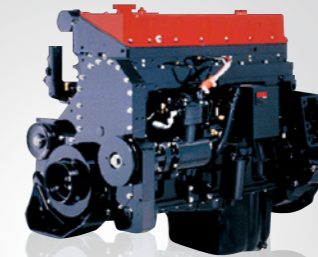

The QSM 11 low-emission engine combines a patented High-Pressure injector system with full-authority electronics for superior low-end performance with a strong torque rise.

- High torque means high manoeuvrability of the loader when moving.
- The engine has two modes of operation: "power" or "economy".

AUTOMATIC TRANSMISSION

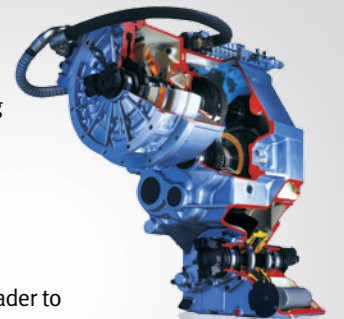

The transmission is particularly smooth and the gear ratios are optimised. There are no shocks, resulting in an appreciable level of comfort for the operator. The traction force is optimum under all working conditions. The combination of these characteristics enables the loader to maintain high speed under all conditions and favours penetration and thus optimum bucket filling at each cycle.

- The transmission has three modes of operation:
- Manual
 - Automatic (automatic shift for all gears)
 - Semi - Automatic (automatic with a "kick down" for first gear)

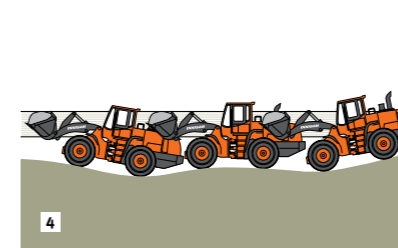
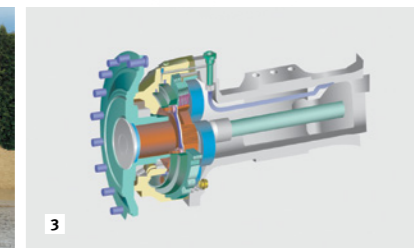

1 HIGH LIFT (OPTIONAL)

Better dump reach and height at bucket pivot point.

2 Z KINETICS

The Z lifting geometry is very robust and especially designed for heavy loads. Few moving parts, reduced loads, simplicity, everything contributes to good loader stability. This geometry enables very rapid bucket movements and ensures correct angle positioning in all situations. The rapid bucket dump capability makes it easier to unload adhesive materials.

3 LIMITED SLIP ZF DIFFERENTIAL

The machines axles are fitted with limited-slip differentials at the front and rear. This automatically ensures the maximum tractive effort and easy driving over soft and muddy ground. It also reduces the risk of skidding and, at the same time, prevents excessive tyre wear.

4 LOAD ISOLATION SYSTEM (OPTIONAL)

This system is ideal for all loading and movement situations and increases driver productivity and comfort. It also minimises the amount of material spilt during travelling.

5 HYDRAULIC POWER STEERING

The newly designed steering system ensures smooth steering even in the low engine speed ranges.

- Steering control valve



DURABILITY & RELIABILITY

DL 420

Because the operator knows that the DOOSAN loader is a tough, reliable, product with large power reserves, it can be relied on to work for long periods. For DOOSAN, reliability means above all durability, availability, accessibility and simplicity.

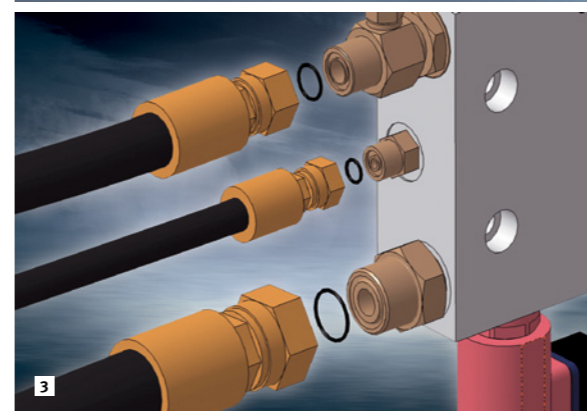
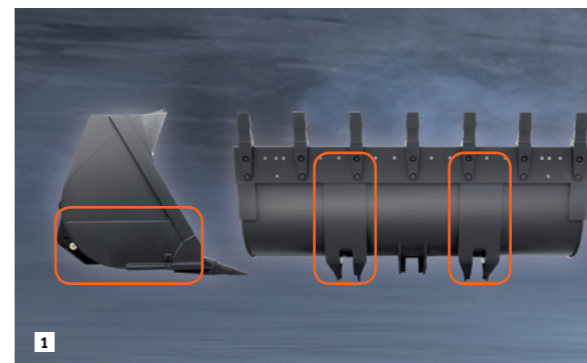

1 REINFORCED BUCKET

The bottom of the bucket are reinforced.

2 RADIATOR GRILL

The radiator grill is made from reinforced steel for increased shock resistance.

3 ORFS

To ensure perfect oil tightness, all ports, even the low pressure ports which are used for the pilot lines, are ORFS type.

4 RADIATORS MOUNTED ON RUBBER MOUNTS

The aluminium radiators are mounted on rubber mounts to effectively withstand vibrations.

5 DRIVE SHAFT

The dust seal has been fitted to protect dust and mud, sand, thus wear during use is reduced. The air vent relief valve is installed against over-filling.

6 DRIVE SHAFT COVER PLATES

- Increased diameter
- Bronze bearings
- Chrome-plated shaft



OPERATOR COMFORT

DL420

A perfect workspace has been created for you. The work rate of the wheel loader is directly linked to the performance of its operator. DOOSAN designed the DL420 by putting the operator at the centre of their development goals. More space, better visibility, air conditioning, a very comfortable seat, sufficient storage space... All these elements ensure that the operator can work for hours in excellent conditions.



VISIBILITY

Visibility has been improved in all directions and the size of the cab has been increased.

AIR CONDITIONING

The high performance air conditioning system provides an air flow which is adjusted and electronically controlled according to the conditions. A double air filter protects the operator's environment. The comfort is comparable to that of a new car.

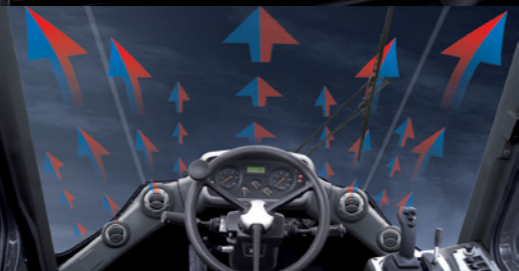

1 STEERING COLUMN

The steering column features both tilting and telescopic functions.

2 ARM REST

Correct positioning with clear controls makes the operator's task easier.

3 CONTROL LEVERS (OPTIONAL)

The control levers are very precise. Different options are available to match what the operator is accustomed to as well as an optional auxiliary lever.

4 LATERAL CONSOLE

The control console is thoughtfully placed to the right of the operator. Provision is provided to fit switches for additional equipment if required.

5 REAR VIEW CAMERA (OPTIONAL)

6 CENTRAL INDICATOR PANEL

A high visibility indicator panel allows the operator to check essential loader functions.

7 SUNVISOR & ROOM MIRROR

AIR-SUSPENSION SEAT (OPTIONAL)

The DL420 is equipped with a very comfortable air suspension seat. Multiple adjustment controls are provided.





EASY MAINTENANCE

DL420

Short, simple maintenance operations at long intervals increase the availability of the equipment on site. DOOSAN has developed the DL420 with a view to high profitability for its user. A detailed design of each detail guarantees optimum reliability and reduced maintenance costs.

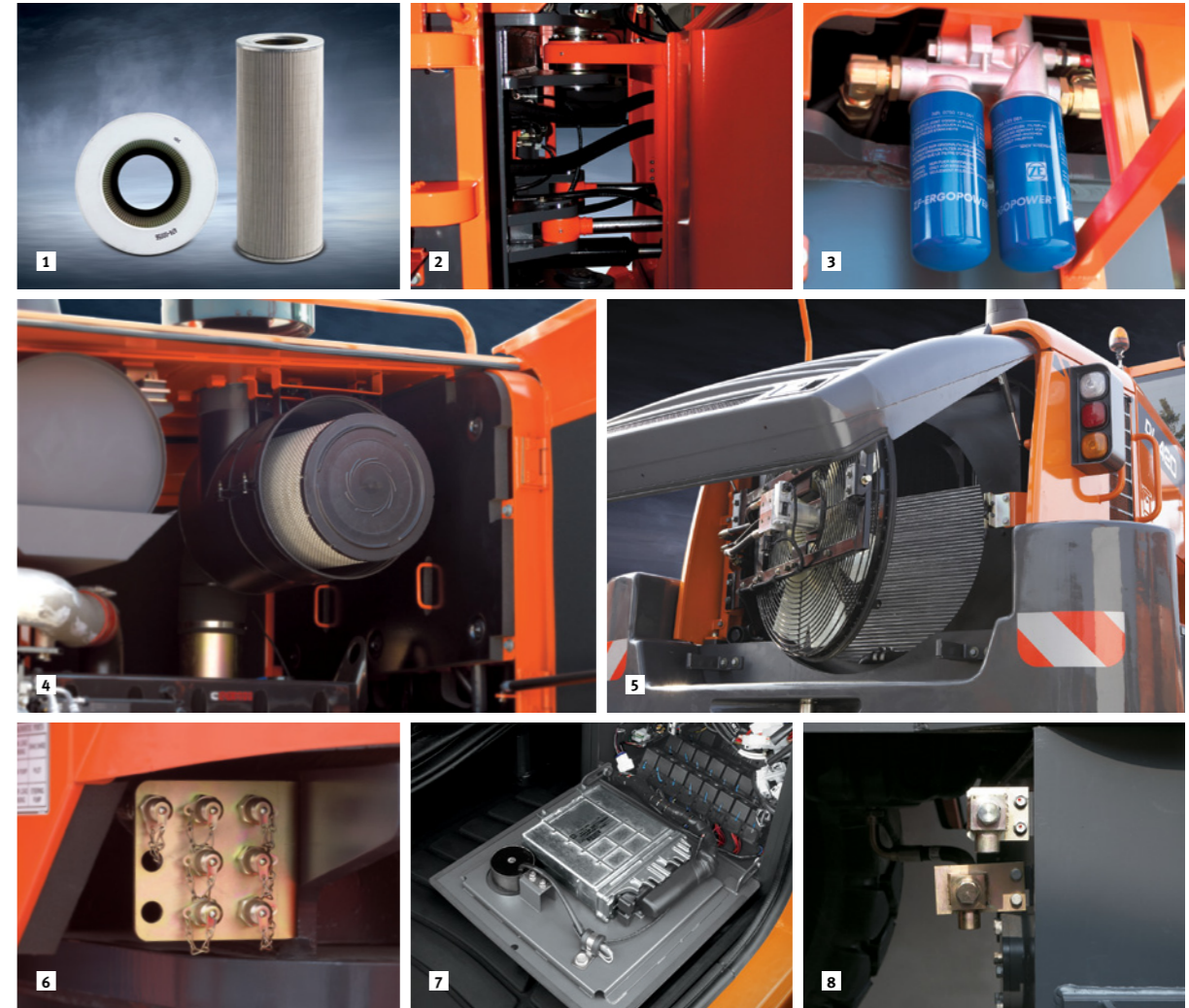

1 HYDRAULIC OIL RETURN FILTER

The high-efficiency, large-capacity return filter manufactured with the glass-fiber media can eliminate foreign substances up to 99.5 percent to protect the costly hydraulic equipment and substantially extend the replacement cycle.

2 CENTRAL JOINTS

The central joints of the machine are particularly robust. The attachment points are positioned to withstand bending and torsion forces. A large amount of space has been left to allow easy access to internal components.

3 TRANSMISSION FILTER

The transmission filters are within easy reach and like the rest of the machine's service components, can be checked from ground level.

4 AIR-CLEANER FILTER

The forced air cleaner removes 99.9% of particles. It is preceded by a high capacity pre-filter. The cleaning and cartridge replacement intervals are very long.

5 REVERSIBLE FAN

The radiator fan has a reversible flow capability to make cleaning of the coolers easier when the machine is operating in dusty environments.

6 HYDRAULIC PRESSURE CHECK POINTS

The pressure test points are grouped together. (Main pressure, steering, braking etc).

7 TRANSMISSION DIAGNOSIS

The transmission can be diagnosed using a laptop computer to interface with the diagnostic system.

8 ENGINE OIL AND COOLANT DRAINS

Drains are installed in very accessible places to facilitate emptying without the risk of polluting the environment.

TELEMATICS SERVICE (OPTIONAL)

GLOBAL PARTS NETWORK

TELECOMMUNICATIONS

Data flow from machine to web



TELEMATICS SERVICE TERMINAL

Telematics Service terminal is installed to machine / connected to EPOS™



TELECOMMUNICATION

GPS, EPOS™ data is sent to designated server by GSM, Satellite telecommunication

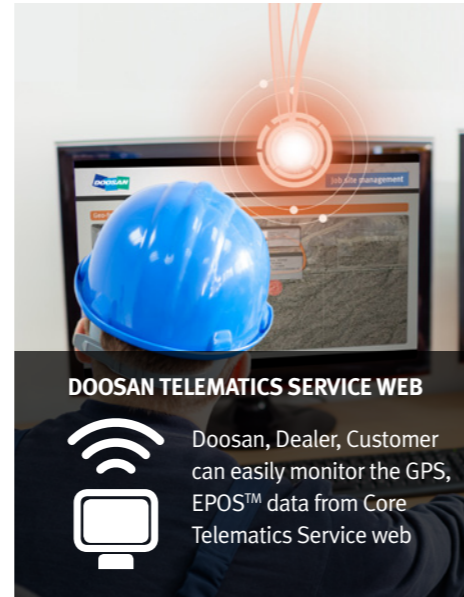

DOOSAN TELEMATICS SERVICE WEB

Doosan, Dealer, Customer can easily monitor the GPS, EPOS™ data from Core Telematics Service web

FUNCTIONS

Doosan Telematics Service provides various functions to support your great performance

TELEMATICS SERVICE BENEFITS

Doosan and dealer support customers to improve work efficiency with timely and responsive services

Customer

- Improve work efficiency
- Timely and preventive service
- Improve operator's skills by comparing work pattern
- Manage fleet more effectively

Dealer

- Better service for customers
- Provide better quality of service
- Maintain machine value
- Better understanding of market needs

Doosan

- Responsive to customer's voice
- Utilize quality-related field data
- Apply customer's usage profile to developing new machine

GLOBAL PDC (PARTS DISTRIBUTION CENTER) NETWORK

Doosan provides fast and precise worldwide delivery of genuine Doosan parts through its global PDC (parts distribution center) network.

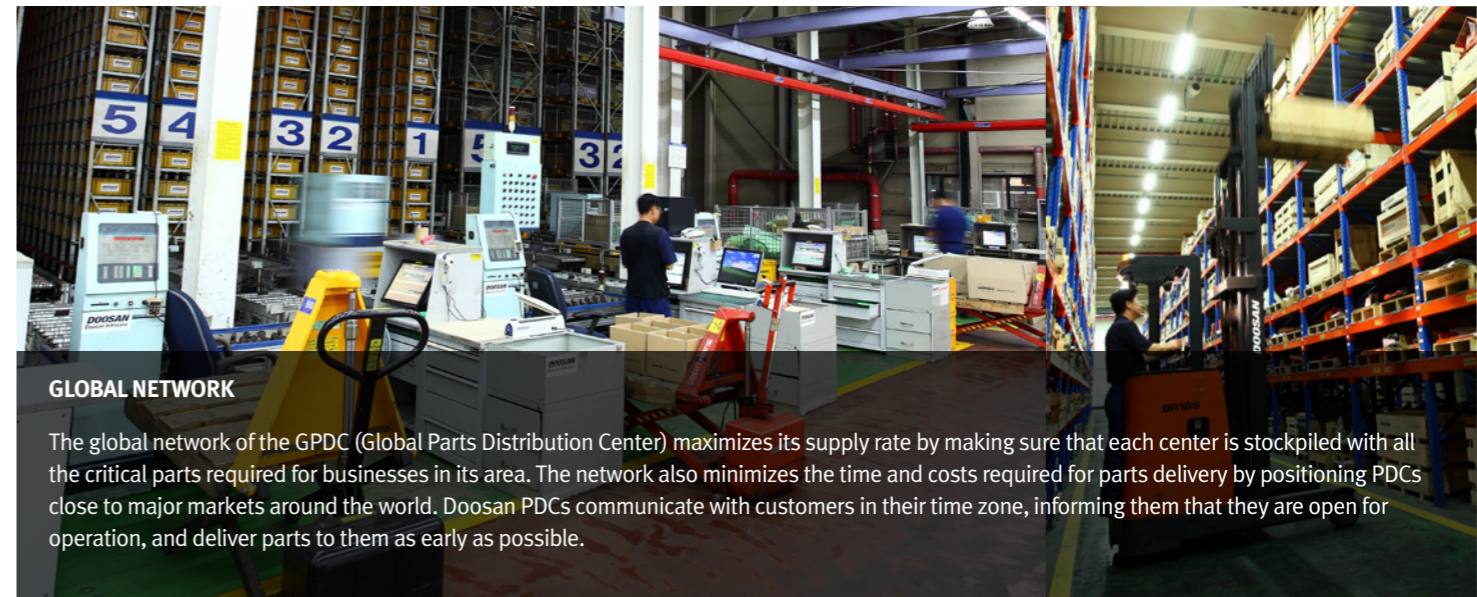

GLOBAL NETWORK

The global network of the GPDC (Global Parts Distribution Center) maximizes its supply rate by making sure that each center is stockpiled with all the critical parts required for businesses in its area. The network also minimizes the time and costs required for parts delivery by positioning PDCs close to major markets around the world. Doosan PDCs communicate with customers in their time zone, informing them that they are open for operation, and deliver parts to them as early as possible.

The Global Parts Distribution Center Network

PDCs had been set up as shown below, including Mother PDC in Ansan, Korea. The seven other PDCs include one in China (Yantai), one in the USA (Chicago), one in Brazil (Campinas), two in Europe (Germany and the UK), one in the Middle East (Dubai), and one in Asia (Singapore).



FUNCTION	EXCAVATOR	WHEEL LOADER	ADT
GPS	All models	All models	All models
E-mail reports	All models	All models	All models
Operation hours	All models	All models	All models
Maintenance parts	All models	Tier 4 only	All models
Fault code/ Warning	All models	Tier 4 only	All models
Fuel information	All models	Tier 4 only	All models
Dump capacity	N/A	N/A	All models

PDC BENEFIT

- Distribution Cost Reduction
- Maximum Parts supply rate
- Shortest distance/time parts delivery
- Real-time service support
- Minimum downtime

TECHNICAL SPECIFICATIONS

ENGINE

General description The high performance Cummins QSM11 combines a 6 cylinder in-line, high-pressure unit injector fuel injection system with electronically controlled direct injection and turbo charged air to air intercooler offers low fuel consumption and emission. (Phase I Area: Cummins QSM11)

-GROSS SAE J1995

Rated Power

209 kW(280 HP) @ 2,000 rpm (SAE J1995, gross)

Max. Power

231 kW(310 HP) @ 1,700 rpm (SAE J1995, gross)

Max. Torque

148 kgf.m (1,450N.m) @ 1,400 rpm

Displacement

10,800 cc (659 cu.in)

Bore x stroke

∅ 125 x 147 mm

Wet replaceable cylinder liners

3 stages Air cleaner including a very efficient precleaner, main and safety elements.

Hydraulically driven puller type fan with possibility of adjustment.

Battery

System voltage : 24 V

Quantity : 12 V x 2

Capacity(AMP) : 150 Ah

Starter power

24 V / 7.5 kW

Alternator

24 V / 70 A

AXLES

The front and rear axles with planetary hub reductions are built on the base of well proven components. Fitted as standard, the front and rear limited slip differentials, ensure the traction is optimal in all circumstances.

Limited slip Differential

Front (30%) / Rear (45%)

Oscillation angle

+/- 11°

Brake

Dual circuit multi-plate wet discs.

Hydraulic actuation with pump and accumulators.

The sintered metal brake discs extend disc service intervals : increased three times.

A spring applied and hydraulically released parking brake is mounted on the transmission shaft.

TRANSMISSION

“Full Power Shift” transmission. That can be used in manual or utomatic modes.

This transmission is based on components having excellent worldwide reputation. It is equipped with a modulation system allowing soft gear shifting and inversion of travel direction. Safety devices also protect the transmission from bad operations.

The gear and direction shifting is operated by a single lever to the left of the steering wheel. A travel direction control is also mounted on the hydraulic joystick.

With a special electronic device, the transmission can be tested and adjusted easily for optimum performance and efficiently.

The transmission can be de-clutched by the operation of brake pedal to increase the power available to the hydraulic pumps.

A safety device prevents the starting of the engine when not in neutral.

Torque converter

Type : Free wheel stator

Stall ratio 2.104

Maximum traction

19.5 ton

Travel speed, kph

Forward : 6.5 - 12.4 - 18.4 - 38 (1 - 2 - 3 - 4)

Reverse : 6.5 - 12.4 - 18.4 (1 - 2 - 3)

HYDRAULIC SYSTEM

Two load-sensing axial piston pumps with variable displacement.

Main control valve of 2 double acting spools is controlled by standard single lever.

Automatic boom kick out and bucket return to dig. Is standard.

All of hydraulic lines are equipped with special seals (ORFS)

Max flow main

200 ℓ/min (52.8 gal/min)

Operating Pressure

250 bars

Pressure of the pilot circuit

30 bars

Filtration capacity on the return line

10 microns

Loading cycles time

Lifting speed (loaded) : 5.8 sec

Dumping speed (loaded) : 1.4 sec

Lowering speed (empty) : 3.0 sec

CAB

The modular cab allows excellent visibility in all directions. The optimal ventilation is obtained by numerous ventilation outlets. Touch buttons control the air re-circulation air conditioning and heating systems. The air of the cab is filtered.

All necessary information for the operator are centralized in front of him. The main functions are actuated via switches located on a console at the right of the operator.

Generous storage places are well located. The cab, mounted on viscous element and equiped with an air suspended seat, offers a better comfort for the operator.

Access door

1

Emergency exits

2

The cab conforms ROPS ISO 3471 and

FOPS : ISO 3449

Guaranteed external noise level Lwa

(following ISO 6395, 2000 / 14 / EC) 104.7 dB(A)

STEERING SYSTEM

The steering system is a load sensing type with a flow amplifier and a priority valve.

Steering angle

40°

Oil flow

200 ℓ/min (52.8 gal/min)

Operating pressure

200 bars

Steering cylinders (2)

bore x stroke : 100 x 450 mm

Emergency steering system with hydraulic pump driven by electric motor. (Optional)

LIFTING SYSTEM

The lifting system with two cylinders and Z configuration is designed for the toughest jobs.

The breakout force (210 kN with a 4.0m³ bucket) is very important and the bucket movements are fast.

The bucket angles are kept in good positions throughout all the range of bucket movements.

Lifting cylinders (2)

bore x stroke : 160 x 928 mm

Bucket cylinders (1)

bore x stroke : 180 x 600 mm

MAINTENANCE

Maintenance is easy due to excellent access.

The transmission is electronically controlled. An error coding system allows easy diagnosis of the systems and proper intervention.

Engine (oil) : 34 ℓ(8.9 US gal)

Radiator (cooling liquid) : 50 ℓ(13.2 US gal)

Fuel : 367 ℓ(97 US gal)

Hydraulic oil : 230 ℓ(60.8 US gal)

Gear box and torque converter : 54 ℓ(14.2 US gal)

Front axle : 51 ℓ(13.5 US gal)

Rear axle : 42.5 ℓ(11.2 US gal)

OPERATIONAL DATA

Loader type			General purpose					Rock	Light material		High Lift
Bucket mount			PIN ON	PIN ON	PIN ON	PIN ON	PIN ON	PIN ON	PIN ON	PIN ON	PIN ON
Configuration	Code	Unit	Teeth (std.)	Bolt-on edge	Teeth	Bolt-on edge	Teeth & segments	Teeth	Teeth	Bolt-on edge	Bolt-on edge
Capacity heaped ISO/SAE		m ³	4.0	4.2	3.7	3.9	4.1	3.5	4.3	4.5	4.2
Tooth type			Adapter tooth	-	Adapter tooth	-	Adapter tooth	Adapter tooth	Adapter tooth	-	-
Bucket width		mm	3,270	3,270	3,040	3,040	3,200	3,231	3,354	3,354	3,270
Breakout force		kN	210	210	220	220	220	210	190	190	205
Static tipping load (straight)		kg	18,190	18,070	18,210	18,087	18,030	17,960	18,120	18,020	15,790
Static tipping load (at full turn)		kg	15,780	15,680	15,790	15,691	15,640	15,580	15,720	15,630	13,700
Dump height (at 45°) (at fully raised) ¹⁾	A	mm	2,960	3,087	2,960	3,087	2,960	2,884	2,802	2,955	3,600
Dump reach (at 45°) (at fully raised) ¹⁾	B	mm	1,400	1,266	1,400	1,266	1,400	1,489	1,567	1,395	1,290
Dump height (at max. dump) (at max. reach) ¹⁾	C	mm	658	860	685	860	685	592	484	689	924
Dump reach (at max. dump) (at max. reach) ¹⁾	D	mm	1,480	1,414	1,480	1,414	1,480	1,537	1,571	1,470	2,068
Digging depth	E	mm	130	130	130	130	130	130	130	130	85
Height at bucket pivot point	F	mm	4,300	4,300	4,300	4,300	4,300	4,300	4,300	4,300	4,807
Max. tilt angle at carry position	G	deg	46.5	46	46	46	46	46	46	46	50
Max. tilt angle at fully raised	H	deg	59	59	59	59	59	59	59	59	60
Max. tilt angle on ground	I	deg	42	42	42	42	42	42	42	42	44
Max. tilt angle at max. reach	J	deg	57	57	57	57	57	57	57	57	57
Max. dump angle at max. reach	K	deg	71	71	71	71	71	71	71	71	60
Max. dump angle on ground	L	deg	64	64	64	64	64	64	64	64	64
Max. dump angle at fully raised	M	deg	46	46	46	46	46	46	46	46	47
External radius at tire side	N	mm	6,350	6,350	6,350	6,350	6,350	6,350	6,350	6,350	6,350
External radius at bucket edge	O	mm	6,995	6,980	6,885	6,870	6,955	6,900	7,080	7,060	7,060
Wheel basis	P	mm	3,500	3,500	3,500	3,500	3,500	3,500	3,500	3,500	3,500
Width at tyres	Q	mm	2,985	2,985	2,985	2,985	2,985	2,985	2,985	2,985	2,985
Tread		mm	2,300	2,300	2,300	2,300	2,300	2,300	2,300	2,300	2,300
Ground clearance	R	mm	520	520	510	510	510	510	510	510	510
Overall length	S	mm	8,880	8,700	8,760	8,635	8,760	8,900	9,020	8,820	9,124
Overall height		mm	3,522	3,522	3,522	3,522	3,522	3,522	3,522	3,522	3,522
Tyre size			26.5-25-20PR (L3)	26.5-25-20PR (L3)	26.5-25-20PR (L3)	26.5-25-20PR (L3)	26.5-25-20PR (L3)	26.5-25-20PR (L3)	26.5-25-20PR (L3)	26.5-25-20PR (L3)	26.5-25-20PR (L3)
Operating weight		kg	22,300	22,400	22,106	22,221	22,457	22,527	22,361	22,467	22,600

1) Measured to the tip of the bucket teeth

DIMENSIONS

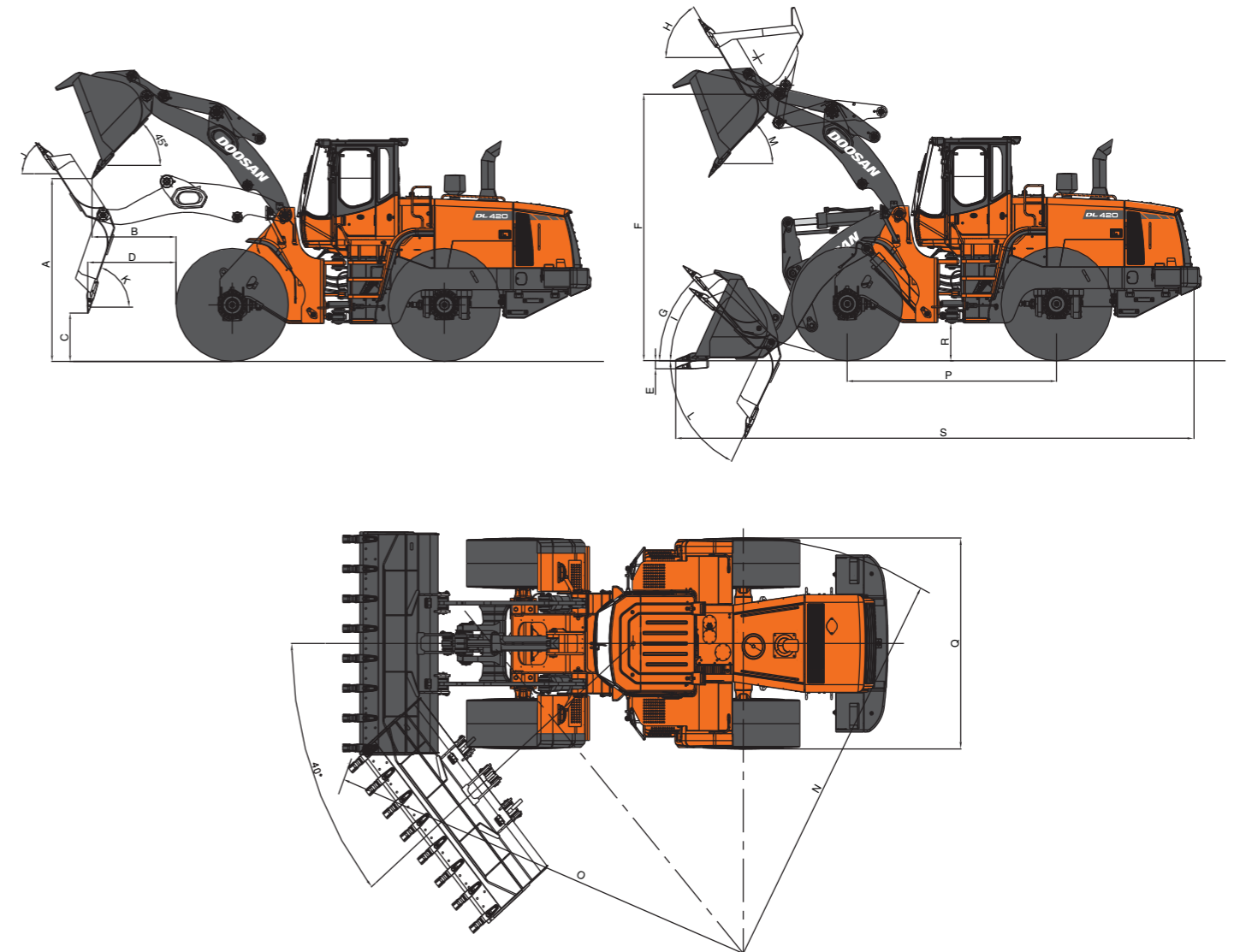

Measured to the tip of the bucket teeth or bolt on edge with tires 26.5R25VMT(L3)

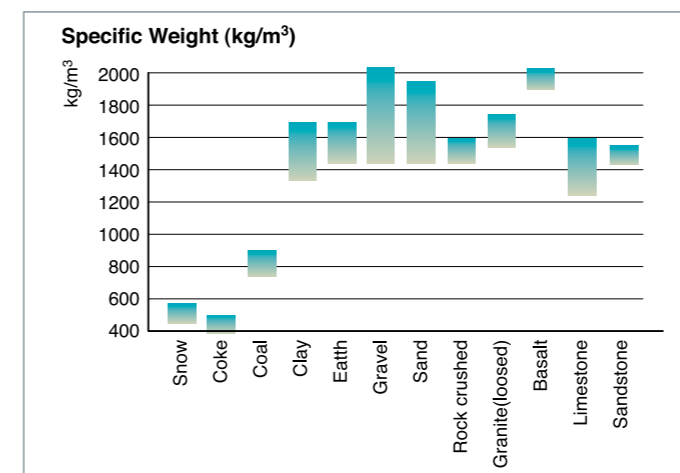

The specific weight of material largely depends on moisture rate, compacting value, percentage of various components etc... This chart is given only for information.

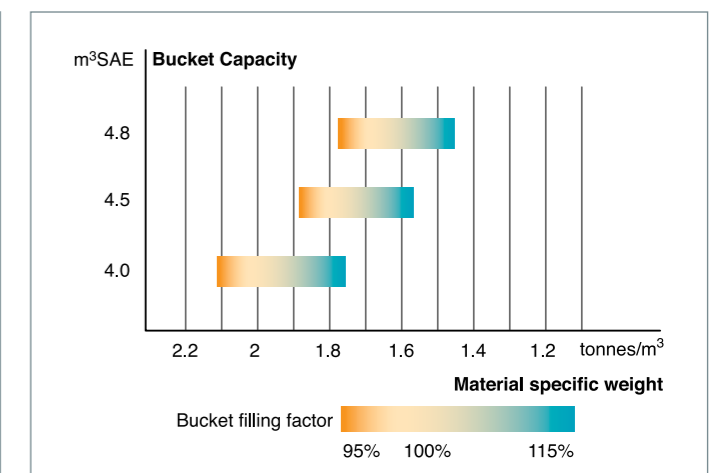

The Bucket filling factor depends also of the nature of material, the working conditions and the operator ability.

STANDARD AND OPTIONAL EQUIPMENT

STANDARD EQUIPMENT

Engine

- CUMMINS QSM11 Diesel engine
- Air cleaner - Double element cartridge + Cyclone filtration in prior stage
- Fuel filter - Main fuel filter and fuel pre-filter with water separator
- External drains for engine oil and coolant changes
- Hydraulic radiator fan - Reversible fan

Hydraulic System

- Hydraulic control valve - 2 spool
- Hydraulic main pump - Variable displacement axial piston
- Hydraulic control levers
- Boom kick out - Automatic
- Bucket return to dig - Automatic

Cabin and Interior

- 12V power socket
- Double filtered air cab
- Air conditioner and heater with recirculation function
- Cup holder
- Tinted glasses
- Floor mat
- AM/FM Radio + MP3(USB)
- Windshield washer front and rear
- Windshield wipers front and rear
- Cigarette lighter
- Multiple storage compartments
- Sun visor
- Glass antenna
- Seat - Mechanical suspension
- ROPS cabin - ISO 3471
- FOPS cabin - ISO 3449
- Adjustable steering column
- Rear view mirrors - Interior 2
- Rear view mirrors - Exterior 2

Electrical and lighting

- Battery cut-off switch
- Working light - Front 2 + Rear 4
- Driving light - Low and high beams
- Tail indicators - Stop, reversing lights
- Reversing alarm
- Electric horn
- Alternator - 24V, 70A
- Self-diagnostic system

Linkage

- Z-bar loader linkage

Drivetrain and Brake system

- Gear shift switch - Manual, Auto 1 ↔ 4, Auto 2 ↔ 4
- Kickdown and travelling direction selection
- Starting safety system
- Dual brake circuits with accumulator
- Dual service brake pedals
- Secondary brake system
- Parking brake - Electrical, hydraulic
- Differential - Limited slip

Steering system

- Load sensing steering system

External equipment

- Fender

OPTIONAL EQUIPMENT

Some of these optional equipments may be standard in some markets. Some of these optional equipments cannot be available on some markets. You must check with the local DOOSAN dealer to know about the availability or to release the adaptation following the needs of the application.

Engine

- Fuel filter - Water separator with heater

Hydraulic System

- Hydraulic Oil - VG32 Cold Weather
- Hydraulic Oil - VG46 Normal Weather
- Hydraulic control valve - 3 spool
- Load isolation system (LIS)
- Hydraulic control levers - Mono
- Hydraulic control levers - FNR
- Hydraulic control levers - Finger tip

Cabin and Interior

- Seat - Air suspension with heater
- Seat - Air suspension
- Camera - Rear view

Electrical and lighting

- License lamp
- Beacon - Rotating
- EMI Filter
- Speed limiter

Linkage

- Z-bar high lift loader linkage

Drivetrain and Brake system

- Axle oil cooler
- Intelligent clutch cut off

Steering system

- Emergency steering pump

External equipment

- Fender - Full fender + rubber protector
- Fender - Rubber protector
- Anti-noise Kit
- Counterweight - 0.3t
- Tool Kit
- Air compressor

ATTACHMENTS

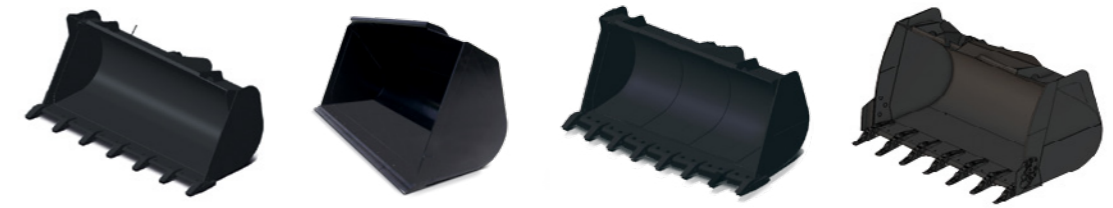

BUCKETS

	General Purpose	Light Material	V-Shape Rock	Material Handler
	Mounting type	Capacity	Width	
GENERAL PURPOSE	Direct mount	3.7 / 3.9 / 4.0 / 4.1 / 4.2 m ³	3,040 / 3,200 / 3,270 mm	
	Quick coupling	3.9 m ³	3,297 mm	
LIGHT MATERIAL	Direct mount	4.3 / 4.5 / 7.0 m ³	3,300 / 3,354 mm	
	Quick coupling	7.0 m ³	3,300 mm	
V-SHAPE ROCK	Direct mount	3.5 m ³	3,230 mm	
	Quick coupling	3.9 m ³	3,297 mm	
MATERIAL HANDLER	Direct mount	4.0 / 4.2 / 4.5 / 4.7m ³	3,270 / 3,270 / 3,354 / 3,354 mm	



Quick Coupler

CONNECTING

	Model	Mounting type	Weight
QUICK COUPLER	Quick coupling	DLQC42	760 kg



Pallet Fork



General purpose



Tropical type
Log Grapple



Sorting type

MATERIAL HANDLING

	Model	Length
PALLET FORK	DLPF42	60" / 72"

	Model	Type
LOG GRAPPLE	DLLG42	General purpose Tropical Sorting type

* Standard specification and options may vary by country.

** Specification is subject to change without prior notice for quality enhancement.

Doosan is

Since 1896, Doosan, the oldest company in Korea, has evolved with its people. The company grew up rapidly for last 10 years with reputation. For human-oriented vision, Doosan has been building constructions, energy, machines, infra structures globally. As a global leader of infra structure, Doosan continues its vision to make human-oriented future.

First in Korea, Doosan self-developed excavators in 1985 and continued building versatile construction machines including excavators, wheel loaders, articulated dump trucks to execute its human-oriented philosophy. Doosan became a global leader of heavy construction machine industry by achieving global sales line, producing line, and distribution line. Along with large production bases in Korea, China, USA, Belgium, Czech, Brazil, Doosan has 1400 dealer networks and Doosan is providing reliable products and trusted solutions for your stable business at no risk.

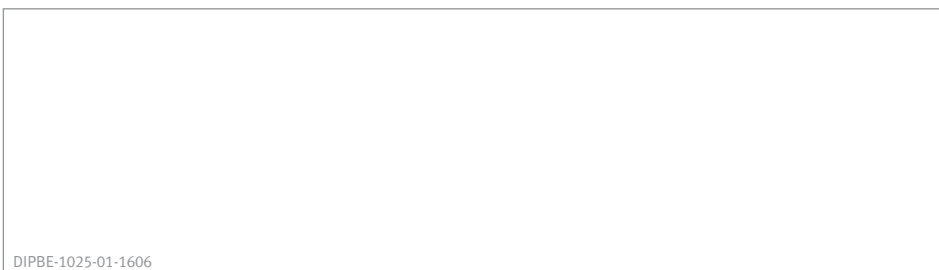

Doosan Infracore Korea Office (HQ)
27F, Doosan Tower, 275, Jangchungdan-ro,
Jung-gu, Seoul, Korea(04563)
Tel : 82 2 3398 8114

www.doosaninfracore.com/ce/

DIPBE-1025-01-1606

Materials and Specifications in the catalogue are subject to change without notice.