

Get in touch today for sales enquiries or further information

CONTACT US

0800 30 30 90 [abequipment.co.nz](http://abequipment.co.nz)



**DOOSAN**

Construction Equipment

# DL200A-7M

## Powered by Innovation

Certain specification(s) are based on engineering calculations and are not actual measurements. Specification(s) are provided for comparison purposes only and are subject to change without notice. Specification(s) for your individual Doosan equipment will vary based on normal variations in design, manufacturing, operating conditions, and other factors. Pictures of Doosan units may show other than standard equipment.

**DOOSAN**

Hyundai Doosan Infracore

489 Injung-ro, Dong-gu, Incheon, South Korea  
<http://global.doosanequipment.com>

DIPBE-00-2112

Hyundai Doosan Infracore is an affiliate of Hyundai Heavy Industries Group.  
The Doosan trademark, **DOOSAN**, is used under license from Doosan Corporation.

Photos may include optional equipment

Powered by Innovation

# A BOLD NEW RULE, FOR ULTIMATE PERFORMANCE

## DL200A-7M

A New Rule for Productivity, A Big Leap for Success  
Presenting the Clear Blueprint for a Perfect Performance

The statement of reliability,  
Doosan is here for you with  
complete solution for your business.

### A BEGINNING AND CLOSURE OF PERFORMANCE

DL200A-7M is ready to push the boundaries of the performance. Limitless engine power, amplified by impressive torque. Athletic balance and precise steering harmonized with power to work energetically. Feel the pure thrill of total performance.

### COMFORT BRINGING AN EXCLAMATION

DL200A-7M offers features which meet both emotional and technical needs for operator. To procure intuitive command center for a performance, all machine interfaces are ergonomically positioned within easy reach. Its functional and intuitive in-and-out design delivers you comfort and total control

### A QUOTE FOR QUALITY AND DURABILITY

Exquisitely grinded and processed, especially robust and efficient. DL200A-7M is built with longevity front of mind. Obsessive engineering and countless tests make an equipment you can count on to cope with the most demanding work environments.

When the normal rules are not enough. Doosan set a new construction grammar of 'New 7M Series' grounded on the exceptional functionality. Innovative materials and technology merged in a visionary form. DL200A-7M, a dynamic new blueprint for all wheel loader models should follow.

A Question. Constant doubt and ceaseless study for performance to look beyond the obvious. An exclamation. Unmistakable presence with all new styling, impressive digging force and tractive power. A pause. Spacing comfort for both unflagging work and revitalizing rest. A quotation. An Epitome of true performer with invigorating engine power, but thoroughly orchestrated through right technologies. A period. Finally, providing the sum of Doosan's legacy, distilled into uncompromising stand.

Take the big leap for new rules. DL200A-7M, an epic start of a new generation. Discover the assertive new style and roaring performance.



# WE ARE BACK WITH NEW FEATURES

All the nice features of previous model bodily succeeded, even nicer things to come

## CABIN VISIBILITY

Improved visibility to the Left and right bottom section of the front windshield for easy positioning of front wheels.

## ADDITIONAL BUCKET (OPTIONAL)

Extra bucket options for further customer choices. 2.2m<sup>3</sup> and 2.3m<sup>3</sup> options added to previous models.

## REINFORCED BUCKET

The lower and side panels of the bucket have been reinforced with additional plates as standard. Reinforcement applied at both sides and at lower panel.

## AUTOMATIC REVERSE FAN (OPTIONAL)

The optional reversible functionality of the fan, which blows air in the opposite direction, allows self-cleaning of the cooling units.

## LSD(Limited Slip Differential)

Various axle option available for different terrain conditions to meet your needs.

## STRENGTH AND INTELLIGENCE

With tremendous lift height and capacity, along with enough torque to bite into the toughest materials, Doosan wheel loaders go a step beyond scooping, carrying and loading. It's your ticket to making harder work easier, longer days more enjoyable, and every minute more productive and profitable.

## AIR SUSPENSION SEAT (OPTIONAL)

The optional, air-suspended seat provides pleasant seating conditions and a high level of comfort.

## DOOSANCONNECT® TELEMATICS SERVICE (OPTIONAL)

Offering 'preventive maintenance service' based on machine operating data. Providing an expert level consultation to dealers. Functioning as fleet management tool for the customers.

## NEW CLUSTER AND KEYPAD

Intuitive gauge panel and keypad enable easy access to machine settings and maintenance data. All switches and operating mechanism integrated to improve operational convenience.

## ENHANCED LIS (LOAD ISOLATION SYSTEM)(OPTIONAL)

LIS absorbs the impact on the lifting arm, cutting off the shock not to be transferred to cabin and body. Enhancing the balance, productivity and operator comfort.

## REAR-VIEW CAMERA (OPTIONAL)

Large and bright LCD monitor to view rear surroundings for safe operation. Wide angle Rear-view camera integrated into the radiator grille, offering seamless design and protection.

# PUREST FORM OF TRUE WORKHORSE

**A Competent Hand, Site-Born DL200A-7M  
Pushing the Boundaries of Performance and efficiency**



To truly set the form of performance, DL200A-7M is engineered to turn raw figure of engine power into invigorative performance to thrill you. A site-born heritage and newly added features thoroughly blend into enhance productivity. Enlarged bucket, lifting capacity and more load capabilities all combined to excellent penetration power and ensures maximum bucket load on every cycle.

Finely orchestrated and controlled power with the balance of maneuverability ensures you to handle any picky environment. Stability and mobility reinforced further by improved LSD (Limited-Slip Differentials). Through right transmission and innovative features that help keep the power where it belongs, DL200A-7M is also extremely efficient. Bring you both unparalleled performance and efficiency, DL200A-7M will be the perfect seed for your flourished harvest.



**DOOSAN ENGINE (DB58TIS)**

DL200A-7M gives high performance through in-house engine. Outputs of 121kw, one of the highest in class. High power and impressive torque range enables to precisely deliver the stable working speed. Reliable and robust mechanical engine provides high resistance to exterior contamination. Perfectly harmonized with the hydraulic system and provides strong power delivers maximum productivity and profitability



**LSD (LIMITED SLIP DIFFERENTIAL)**

The front and rear axles are fitted with limited-slip differential provides 45% locking ratio. This automatically ensures the maximum tractive effort and easy driving over soft and swampy ground.



**HIGH LIFT (OPTIONAL)**

With the high lift customers can have further choices with additional lift height and reach. Easily load into high-sided trucks or mixers. High lift is ideal for recycling facilities, and agricultural operations.



**FULL AUTO TRANSMISSION**

The electronic powershift transmission is particularly smooth. Gear ratios perfectly spaced to give optimal speed. It gives comfort and delivering excellent traction in every working condition. Providing three modes of operation, 'Manual', 'Automatic' and 'Semi-Automatic'. 'Automatic' mode provides self regulative shift for all gears and 'Semi- Automatic' mode provides automatic option after the first acceleration and gear shift.



**IMPROVED LIS (LOAD ISOLATION SYSTEM)**

In loaded traveling, the impact on the front could be transferred to the body, may give rise to equipment damage and driver uncomfortableness. LIS option absorbs tremor and minimizes swaying movement of lifting arm while the equipment carries the load. Ultimately enhancing the durability of front structure and operator's comfort.



**HYDRAULIC POWER STEERING**

The newly designed steering system ensures smooth steering even in the low engine speed ranges. Prepared with steering control valve.

# THE DEFINITION OF UNCOMPROMISING QUALITY

## Ever Lasting Value With Reliability Equipped in Standard

To thoroughly respond to the harsh natural forces, DL200A-7M is here to support you with the best quality components for the job. We craft more powerful, and durable components with DL200A-7M to handle the most severe, heavy-duty applications. Designing axles and components to the optimum shape to aptly incarnate engine power. Obsessive engineering and countless tests to articulate how structures stand with external forces and how it performs.

The lasting value with high quality and outstanding reliability. DL200A-7M is engineered and tuned for unflagging performance. Rigorous quality standard applied to remote possibilities in hydraulic components and all key frame structures. Doosan is more than ready to provide an especially robust equipment that can go beyond almost any construction challenge.

### APPLIED MORE RIGOROUS QUALITY STANDARD

All key components meet the increased new quality standard. Applying Doosan single platform, which verified in advanced market.

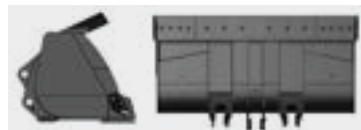

### REINFORCED BUCKET

The lower and side panels of the bucket have been reinforced with additional plates as standard. Reinforcement applied at both sides and at lower panel.



### ORFS-ALL PORTS

To ensure perfect oil tightness, all ports, are fitted with ORFS type. Even in the low pressure ports such as pilot line and pressure line are ORFS type.



### FORTIFIED AXLE DURABILITY FOR HEAVY DUTY OPERATION

The brake discs have been repositioned to the rear part of the reduction gear, where rotation speed is lower. Improved internal oil flow prevents premature disc wear due to overheating of the internal hub components. Higher intense axles were applied for excellent stability and traction on even the roughest terrain.

### RADIATOR GRILLE WITH STEEL STRUCTURE

The radiator grill with its aerodynamic steel structure increases air flow which facilitates cooling and the maintenance process



### RADIATORS MOUNTED ON RUBBER MOUNTS

The radiators are mounted on rubber mounts to effectively withstand vibrations.



### REMOTE AXLE BREATHER

Increased the height of front axle breather for prevention of pollution from particle matter. Added additional remote type axle breather on rear axle.





# IDEAL CONDITION FOR STRENUOUS WORK

## **Intuitive Little Details and High Technology, Feels Like the Natural Extension Of Own Body**

Sometimes it is the little details that help make work easier. DL200A-7M offers features which meet both emotional and technical needs for operator. To procure intuitive command center, all machine interfaces are ergonomically positioned within easy reach. With functions and information minimized into a simple gauge panel, you can naturally concentrate on what you really need to see.

DL200A-7M provides an ample space of refinement, with features made of authentic materials and craftsmanship. Completely re-designed cabin with climate control systems, air suspension seat and optional safety features. All offered for outstanding comfort and to assure protective and adaptive working environment. Your haven keeps you revitalized to work for strenuously without feeling tired.



### SPACIOUS CABIN COMFORT

Refined interior with enhanced legroom and extendable storage space guarantees a serene ride to you. A more orderly interior Equipped with high-class designed upholstery and thoroughly changed comfort accessories. This ensures operator to have a clear and uncluttered workplace at all times.

### 1. ALL AROUND VISIBILITY

Improved visibility to the Left and right bottom section of the front windshield for easy positioning of front wheels.

### 2. AIR CONDITIONING

The high performance of air conditioning system provides an air flow which is adjusted and electronically controlled according to the conditions. A double air filter protects the operator's environment.

### 3. SMALL DETAILS ADD THE FEELING OF REFINEMENT

Operationally re-designed brake pedal and non-slip floor mat equipped. Heating and ventilation, Air conditioning system upgraded for pleasant environment. USB charger and sunglass case is also equipped for additional comfort. Rear sun visor is also equipped for UV protection.

### 4. SUSPENSION SEAT (OPTIONAL)

The optional, air- suspended seat provides pleasant seating conditions and a high level of comfort.

### 5. CABIN BOOK LAMP

Book lamp placed near the cabin door to secure operator's visibility by preventing the shadow. This new book lamp contributes to enhanced safety through improved illumination of the way. Enhances driving comfort and safety.

### 6. REAR VIEW CAMERA (OPTIONAL)

Optional rear-view camera increases safety by giving visibility beyond operator's sight. Additional LED lighting system attached on each side for the clear identification.

### 7. THUMBWHEEL JOYSTICK

Joystick enables united and intuitive control of your wheel loader.

### 8. CENTRAL GAUGE PANEL

A new gauge panel put essential information right in front of the driver. The compact central monitor clearly shows the perfect overview of the machine status and warning messages at a single glance.



- 1. ALL AROUND VISIBILITY
- 2. AIR CONDITIONING
- 3. SMALL DETAILS ADD THE FEELING OF REFINEMENT
- 4. SUSPENSION SEAT (OPTIONAL)
- 5. CABIN BOOK LAMP
- 6. REAR VIEW CAMERA (OPTIONAL)
- 7. STEERING COLUMN AND THUMBWHEEL JOYSTICK
- 8. CENTRAL GAUGE PANEL



# GEARED FOR UPTIME, SIMPLE MAINTAINANCE

## Lowering the Entry Barrier of Maintenance, Driving Up the Operating Time

For maximum machine uptime, the first key is to build the impervious and durable components. However, it is an equally important key to remain optimum operating condition by regular maintenance. DL200A-7M offers features to operate in best condition at long intervals by ensuring short and easy maintenance procedure.

The mechanical engine, ground accessible filters and simple layout lower the entry barrier of access. Centralized grease inlets are designed for simple routine maintenance. Extensive service network and expert assistance are also readily available, DoosanCONNECT® provides you broad range of service to get the most productivity out of your equipment.



### 1. CENTRAL JOINTS

The central joints of the machine are particularly robust. The attachment points are positioned to withstand bending and torsion forces. A large amount of space has been left to allow easy access to internal components.



### 2. WIDE FIN RADIATOR

cooling fan regulates the temperature of the vital components. Wide fin pitch radiators coupling with reversible fan keep the cooling system performing constantly - minimizing machine downtime and reducing daily maintenance.

### 3. DOOSANCONNECT®

Allowing various parameters to be checked during maintenance procedure, such as pump pressure and engine rotation speed. Parameters can be stored and printed for subsequent analysis.





#### 4. REMOTE GREASING LUBRICATION PORTS

Front pins can be lubricated from the outside of the machine. Enable to skip the unnecessary procedure of struggling to reach the unapproachable lubrication ports, including crawling under the machine.

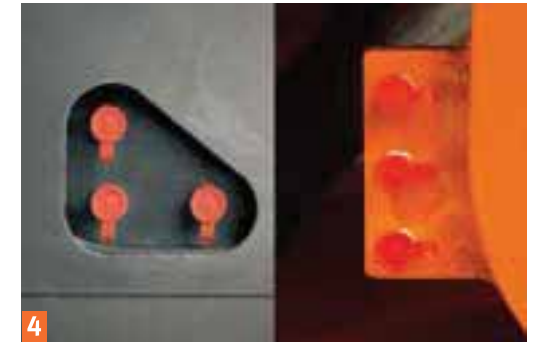

#### 5. TRANSMISSION FILTER

Transmission filters located in easy reach. Like the rest of the machine's service components, can be checked from ground level.



#### 6. TRIPLE-ELEMENT AIR CLEANER FILTER

Maintenance-free cyclone air pre-filter separates more than 99% of particles 20 microns in size and larger. Extending the air filter's lifetime, the pre-filter also ensures better combustion and a longer engine lifetime.



#### 7. ENGINE OIL/COOLANT DRAIN PORT

Remote type drain ports makes it easier to replace engine oil/coolant.



#### 8. AUTOMATIC REVERSE FAN (OPTIONAL)

The optional reversible functionality of the fan, which blows air in the opposite direction, allows self-cleaning of the cooling units. Electronically controlled, tolerant for a range of conditions including dusty, sturdy, harsh environments. Reducing the risk of contamination and lengthen the change intervals.

# DoosanCONNECT® Telematics Service (OPTIONAL)

**TELECOMMUNICATIONS** Data flow from machine to web



### TELEMATICS SERVICE TERMINAL

Telematics Service terminal is installed to machine / connected to EPOS™

### TELECOMMUNICATION

GPS, EPOS™ data is sent to designated server by GSM, Satellite telecommunication

### DOOSAN TELEMATICS SERVICE WEB

Doosan, Dealer, Customer can easily monitor the GPS, EPOS™ data from Core Telematics Service web

**TELEMATICS SERVICE BENEFITS** Doosan and dealer support customers to improve work efficiency with timely and responsive services

#### CUSTOMER

- Improve work efficiency
- Timely and preventive service
- Improve operator's skills by comparing work pattern
- Manage fleet more effectively

#### DEALER

- Better service for customers
- Provide better quality of service
- Maintain machine value
- Better understanding of market needs

#### DOOSAN

- Responsive to customer's voice
- Utilize quality-related field data
- Apply customer's usage profile to developing new machine

**FUNCTIONS(WEB/APP)** Doosan Telematics Service provides various functions to support your great performance



- GPS
- Fuel information
- Preventive maintenance
- Operation hours



- Fault code/warning
- ADT Productivity
- Reports

FUNCTION	EXCAVATOR	WHEEL LOADER	ADT
GPS	All models	All models	All models
Operation hours	All models	All models	All models
Maintenance parts	All models	Tier 4 only	All models
Fault code/ Warning	All models	Tier 4 only	All models
Fuel information	All models	Tier 4 only	All models
Dump capacity	N/A	N/A	All models

# GLOBAL PARTS NETWORK

## QUALITY-PROVEN MAIN COMPONENTS

Doosan provides fast and precise worldwide delivery of genuine Doosan parts through its global PDC (parts distribution center) network.



### GLOBAL NETWORK

The global network of the GPDC (Global Parts Distribution Center) maximizes its supply rate by making sure that each center is stockpiled with all the critical parts required for businesses in its area. The network also minimizes the time and costs required for parts delivery by positioning PDCs close to major markets around the world. Doosan PDCs communicate with customers in their time zone, informing them that they are open for operation, and deliver parts to them as early as possible.

## THE GLOBAL PARTS DISTRIBUTION CENTER NETWORK

PDCs had been set up as shown below, including Mother PDC in Ansan, Korea. The nine other PDCs include one in China (Yantai), Four in USA (Seattle and Atlanta, Suwanee, Miami), two in Europe (Germany and the UK), one in the Middle East (Dubai) and one in Asia (Singapore).

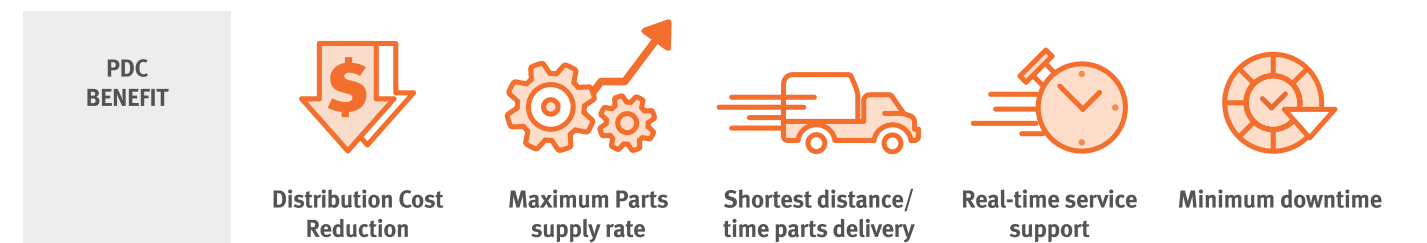

# ATTACHMENTS

Aggregate bucket is the most commonly used bucket in the construction equipment market and is designed mainly for use in heavy construction but also used in low density mining and quarry application.

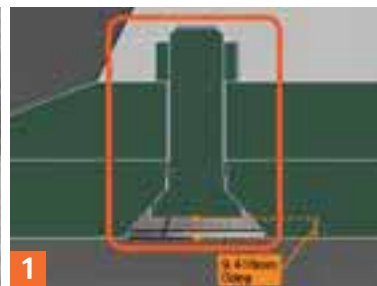
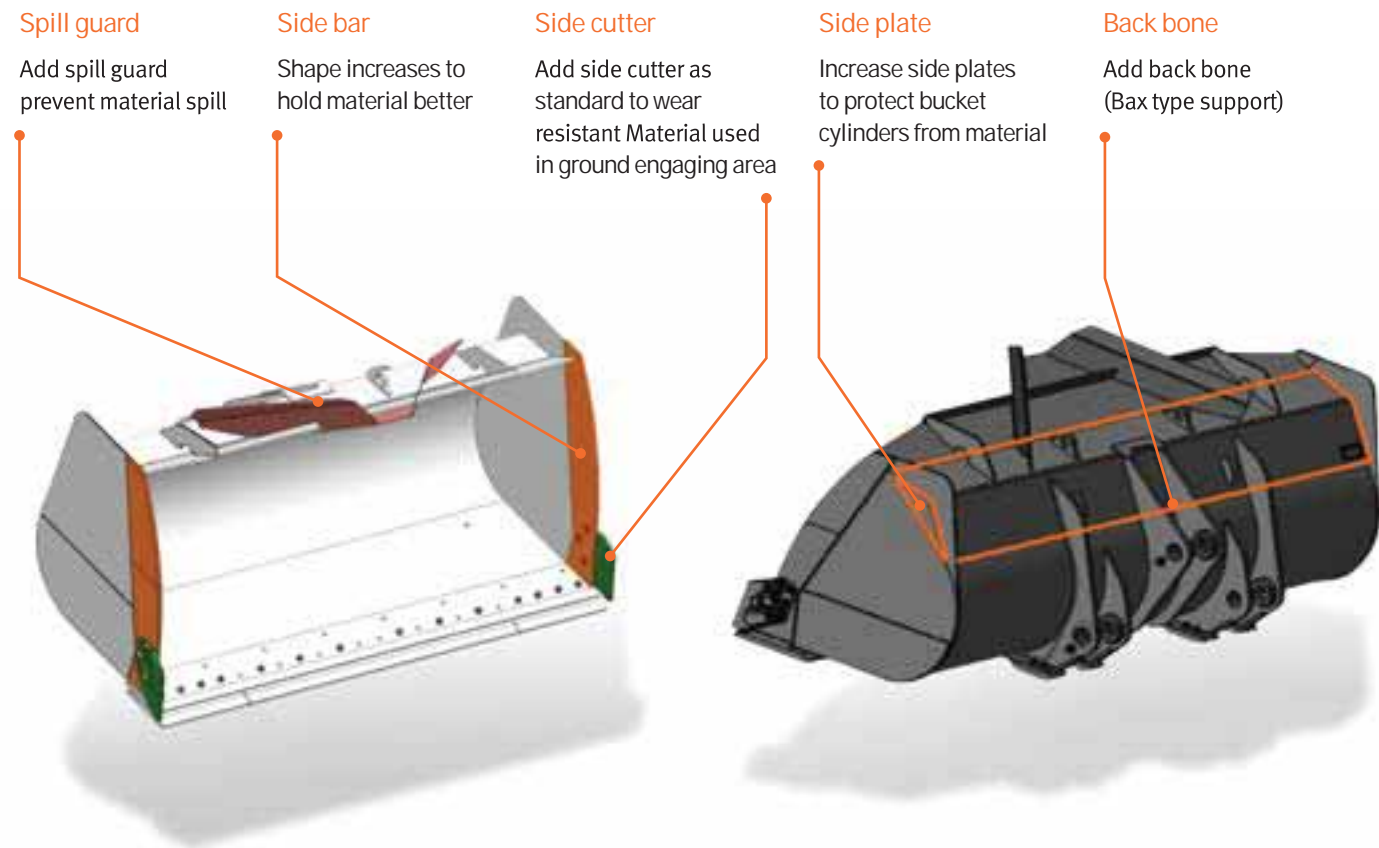

**PLOW BOLT FOR CHANGEABLE PARTS**  
New plow bolt will be applied on tooth adaptor and cutting edge

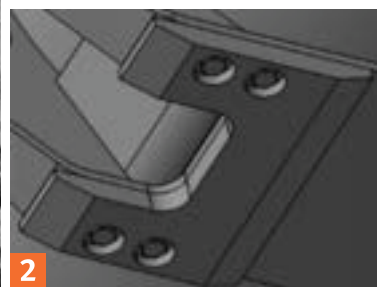

**CHANGEABLE BOTTOM PLATES**  
Operator can change wear plate easily



General Purpose



Light Material

## BUCKETS

	DLGP20	DLLM20
WEIGHT [kg]	779	1,218
CAPACITY [m <sup>3</sup> ]	2.0	4.0



## QUICK COUPLER

	DLQC20
WEIGHT [kg]	340



## PALLET FORK

	DLPF20
WEIGHT [kg]	690 / 735
LENGTH [inch]	48 / 60
OPERATING WIDTH [mm]	450~2,030



## LIFTING ARM

	DLLA20
WEIGHT [kg]	470
LOAD [kg] (REACH [m])	3,000 (3.6) / 2,000 (4.6) / 1,400 (5.8)



General Purpose

General purpose grapples is an all-round grapple for handling and sorting entire trees or for grabbing single stem.



Tropical

tropical timber grapples are very wide with two separate clamping arms to hold large, heavy items securely. principally intended for handling large diameter and high density tropical type timbers.



Sorting

sorting type grapple has relatively long and straight tines so the grapple can be easily filled when loading from stacks or sorting bunkers. Both the Unloading and the sorting grapple can be fitted with a hydraulic heel/kick out.

## LOG GRAPPLE

	DLLG20	
WEIGHT (kg)	1,250	1,250
LOG DIA. Ø (mm)	300	1,200

# TECHNICAL SPECIFICATION

## ENGINE

The high performance Doosan DB58TIS 6 cylinder, direct injection, turbo charged, air-air intercooler engine offers low fuel consumption and low exhaust emissions.

### Rated Power

Gross 121 kW @2,100 rpm (ISO14396, SAE J1995)  
Net 121 kW @2,100 rpm (ISO9249, SAEJ1349)

### Max Torque

638 N.m @ 1,400 rpm

### Displacement

5,785 cc (492 cu.in)

### Bore x stroke

Ø 102 X 118 mm

3 stages Air cleaner including a very efficient pre-cleaner, main and safety elements.

Hydraulically driven puller type fan with possibility of adjustment.

### Battery

System voltage : 24 V

Quantity : 12 V x 2

Capacity (AMP) : 100 Ah

### Starter power

24 V / 4.5 kW

### Alternator output

24 V / 80 A

## AXLES

The front and rear axles with planetary hub reductions are built on the base of very reputed components. Fitted as standard, the front and rear limited slip differentials, ensure the traction is optimal in all circumstances.

### Type

Fully floating planetary-type

### Limited slip Differential (front and rear)

45 %

### Oscillation angle

+/- 11°

### Brake

Dual circuit multi-plate wet discs.  
Hydraulic actuation with pump and accumulator.  
A spring applied and hydraulically released parking brake is mounted on the front axle.

## TRANSMISSION

“Full Power Shift” transmission. It can be used in manual or automatic modes.

This transmission is based on components having excellent worldwide reputations. It is equipped with a modulation system allowing soft gear shifting and inversion of travel direction. Safety devices also protect the transmission of bad operations. The gear and direction shifting is operated by a single lever to the left of the steering wheel. A travel direction control is also mounted on the hydraulic joystick. (Optional)

With a special electronic device, the transmission can be tested and adjusted easily for optimum performance and efficiently. The transmission can be de-clutched by the operation of brake pedal to increase the power available to the hydraulic pumps. A safety device prevents the starting of the engine when not in neutral.

### Torque converter

Type : Single stage, one phase,  
Stall ratio : 2.911

### Travel speed, kph

Forward : 7.5 · 13.3 · 23.1 · 36.2  
Reverse : 7.9 · 13.9 · 24.2

## HYDRAULIC SYSTEM

The hydraulic system uses triple gear pumps. Pilot actuation with standard single lever.

Automatic arm kick-out is standard.

All of hydraulic lines are equipped with special seals (ORFS)

### Max flow main

194 l/min @ 2,200 rpm

### Working Pressure

215 bars

### Pressure of the pilot circuit

33 bars

### Filtration capacity on the return line

10 microns

### Loading cycles time

Lifting speed (loaded) : 5.7 seconds  
Dumping speed (loaded) : 1.4 seconds  
Lowering speed (empty) : 3.9 seconds

## OPERATOR' CAB

The modular cab allows excellent visibility in all directions. The optimal ventilation is obtained by numerous ventilation outlets. Touch buttons control the air re-circulation air conditioning and heating systems. The air of the cab is filtered.

All necessary information for the operator are centralized in front of him.

The main functions are actuated via switches located on a console at the right of the operator.

Generous storage places are well located. The cab, mounted on viscous element and equipped with an air suspended seat, offers a better comfort for the operator.

Access door : 1

Emergency exits : 2

The cab conforms ROPS ISO 3471 and  
FOPS : ISO 3449

Guaranteed external noise level Lwa

(following ISO 6395) 108 dB(A)

## STEERING

The steering system is load sensing type with steering unit and priority valve.

### Steering angle

40°

### Oil flow

97 l/min @ 2,200 rpm

### Working pressure

180 bars

### Steering cylinders (2)

bore x stroke : 70 X 366 mm  
Emergency steering system with hydraulic pump driven by electric motor. (Optional)

## LIFTING SYSTEM

The lifting system with two cylinders and Z configuration is designed for the toughest jobs. The breakout force is very important and the bucket movements are fast. The bucket angles are well kept in good positions on all the range of bucket movement.

### Lifting cylinders (2)

bore x stroke : 130 X 676 mm

### Bucket cylinders (1)

bore x stroke : 140 X 509 mm

## MAINTENANCE

Maintenance is easy due to excellent access. The transmission is electronically controlled. An error coding system allows easy diagnosis of the systems and proper intervention

Engine (oil) - 21

Radiator (cooling liquid) - 32.7

Fuel - 235

Hydraulic oil - 120 - ST

Gear box and torque converter - 42

Front axle - 15 (2.3X2)

Rear axle - 17 (2.6X2)

# OPERATIONAL DATA

LOADER TYPE		General purpose				High Lift Arm	
BUCKET MOUNT		PIN ON	PIN ON	PIN ON	PIN ON		
Configuration	Unit	Teeth	Bolt-on edge	Teeth	Bolt-on edge		
Capacity heaped ISO/SAE	m <sup>3</sup>	1.9	2.0	2.2	2.3		
Bucket width	D	mm	2,550	2,550	2,550	2,550	
Breakout force	kN	101	95	92	87	+ 1	
Static tipping load (straight)	kg	9,326	9,267	9,356	9,258	- 1,673	
Static tipping load (at full turn)	kg	8,235	8,183	8,262	8,175	- 1,477	
Dump height (at 45°) <sup>1)</sup> (at fully raised)	H(H")	mm	2,690	2,765	2,630	2,695	+ 480
Dump reach (at 45°) <sup>1)</sup> (at fully raised)	I(I")	mm	1,070	1,005	1,135	1,065	- 10
Dump height (at max. dump) <sup>1)</sup>		mm	805	890	725	810	+ 50
Dump height (at max. dump) <sup>1)</sup>		mm	1,390	1,355	1,430	1,385	+ 505
Digging depth		mm	64	58	64	64	142
Height at bucket pivot point	J	mm	3,735	3,735	3,735	3,735	+ 475
Max. tilt angle at carry position	K	deg	49	49	49	49	50.6
Max. tilt angle at fully raised	M	deg	60	60	60	60	62.9
Max. tilt angle on ground		deg	43	43	43	43	43.3
Max. tilt angle at max. reach		deg	59	59	59	59	58
Max. dump angle at max. reach		deg	64	64	64	64	55.9
Max. dump angle on ground		deg	64	64	64	64	58.9
Max. dump angle at fully raised	L	deg	46	46	46	46	44.7
External radius at bucket edge	Q	mm	5,865	5,865	5,865	5,865	+ 200
Ground Clearance at 12° oscillation	T	mm	368	368	368	368	368
Rear Axle to Counter weight	S	mm	1,907	1,907	1,907	1,907	2,081
Overall length without bucket	R	mm	6,255	6,255	6,255	6,255	+ 445
Overall length	A	mm	7,445	7,350	7,530	7,440	+ 440
Operating weight	kg	11,327	11,385	11,385	11,444	+ 188	

1) Measured to the tip of the bucket teeth

# DIMENSIONS

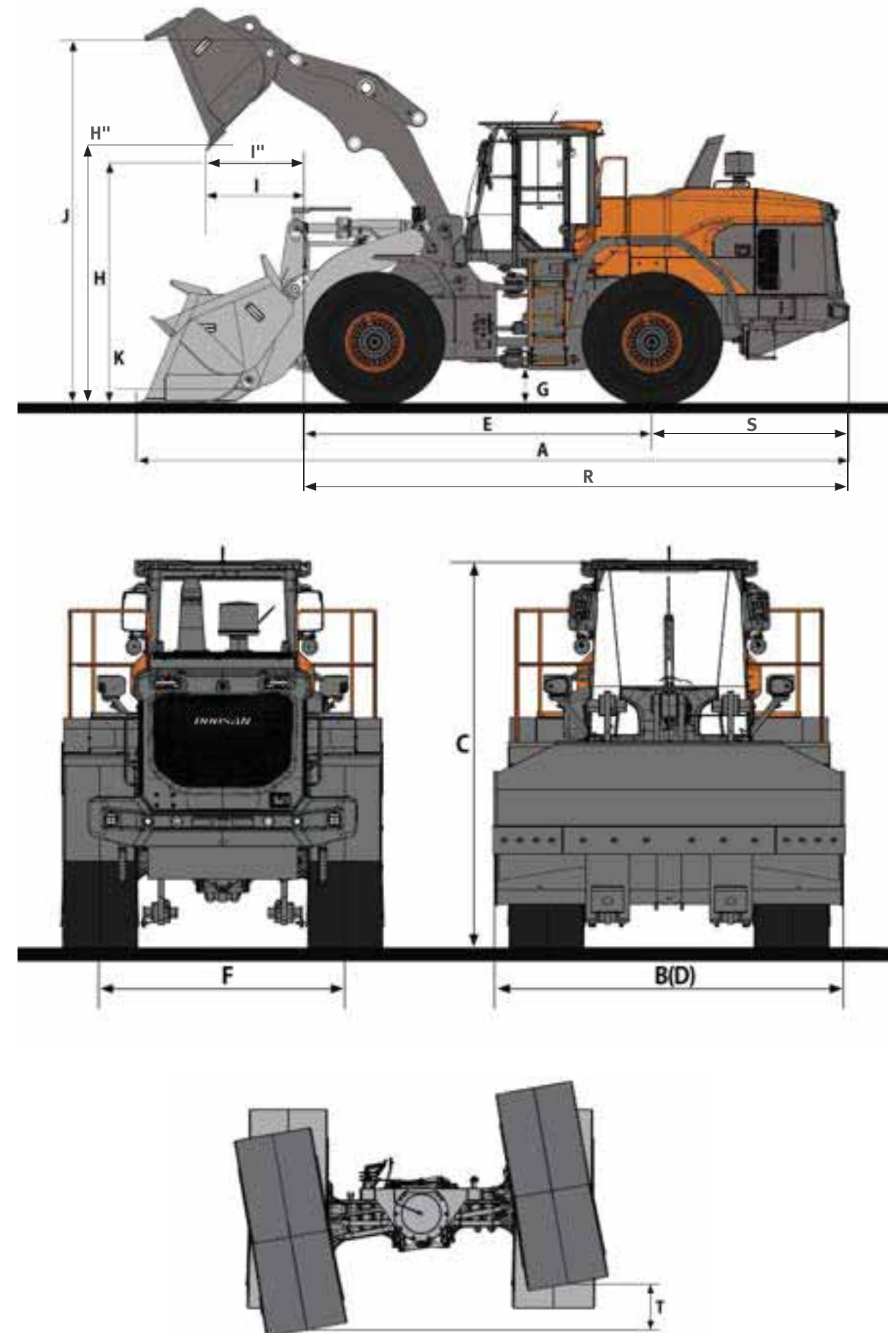

# STANDARD AND OPTIONAL EQUIPMENT

## STANDARD EQUIPMENT

### Engine

- DOOSAN DB58TIS Diesel engine
- Air cleaner - Double element cartridge + Cyclone filtration in prior stage
- Fuel filter - Main fuel filter and fuel pre-filter with water separator
- External drains for engine oil and coolant changes
- Hydraulic radiator fan
- Fuel filler pump

### Hydraulic System

- Hydraulic control valve - 2 spool
- Hydraulic main pump - Triple gear pump
- Hydraulic control levers
- Boom kick out - Automatic
- Bucket return to dig - Automatic

### Cabin and Interior

- 12V power socket
- Double filtered air cab
- Air conditioner and heater with recirculation function
- Dual Cup holder
- USB Charging Port
- Tinted glasses
- Sunglass Case
- Floor mat
- AM/FM Radio + MP3(USB)
- Windshield washer front and rear
- Windshield wipers front and rear
- Cigarette lighter
- Multiple storage compartments
- Front/Rear Sun visor
- Glass antenna
- Seat - Mechanical suspension
- ROPS cabin - ISO 3471
- FOPS cabin - ISO 3449
- Adjustable steering column
- Rear view mirrors - Interior 1
- Rear view mirrors - Exterior 2

\* Standard specification and options may vary by country.

\*\* Specification is subject to change without prior notice for quality enhancement.

### Electrical and lighting

- Battery cut-off switch
- Working light - Front 2 + Rear 2
- Driving light - Low and high beams
- Tail indicators - Stop/Turn/Positioning Lamp
- Reversing alarm
- Electric horn
- Alternator - 24V, 80A
- Self-diagnostic system

### Linkage

- Z-bar loader linkage

### Drivetrain and Brake system

- Gear shift switch - Manual, Auto 1 4, Auto 2 4
- Kickdown and travelling direction selection
- Starting safety system
- Dual brake circuits with accumulator
- Dual service brake pedals
- Secondary brake system
- Parking brake - Electrical, hydraulic

### Steering system

- Load sensing steering system

### External equipment

- Fender

## OPTIONAL EQUIPMENT

Some of these optional equipments may be standard in some markets. Some of these optional equipments cannot be available on some markets. You must check with the local Doosan dealer to know about the availability or to release the adaptation following the needs of the application.

### Hydraulic System

- Hydraulic Oil - VG32 Cold Weather
- Hydraulic Oil - VG46 Normal Weather
- Hydraulic Oil - VG68 Tropical Weather
- Hydraulic control valve - 3 spool
- Load isolation system (LIS)
- Hydraulic control levers - Mono
- Hydraulic control levers - FNR
- Automatic reverse Fan
- Quick coupler piping and switch

### Cabin and Interior

- Seat - Air suspension with heater
- Camera - Rear view

### Electrical and lighting

- License lamp
- Beacon - Rotating
- LED working lamp
- Heated side mirrors

### Linkage

- Z-bar high lift loader linkage

### Drivetrain and Brake system

- LSD Differential
- Thermostat
- Additional brake pedal

### Steering system

- Emergency steering pump

### External equipment

- Fender - Full fender + rubber protector
- Fender - Rubber protector
- Wheel chocks
- Underguard Kit
- Additional counterweight - 0.3 ton
- Tool Kit

Get in touch today for sales enquiries or further information

CONTACT US

0800 30 30 90 [abequipment.co.nz](http://abequipment.co.nz)

