

Dimension

Working Range

Unit : mm

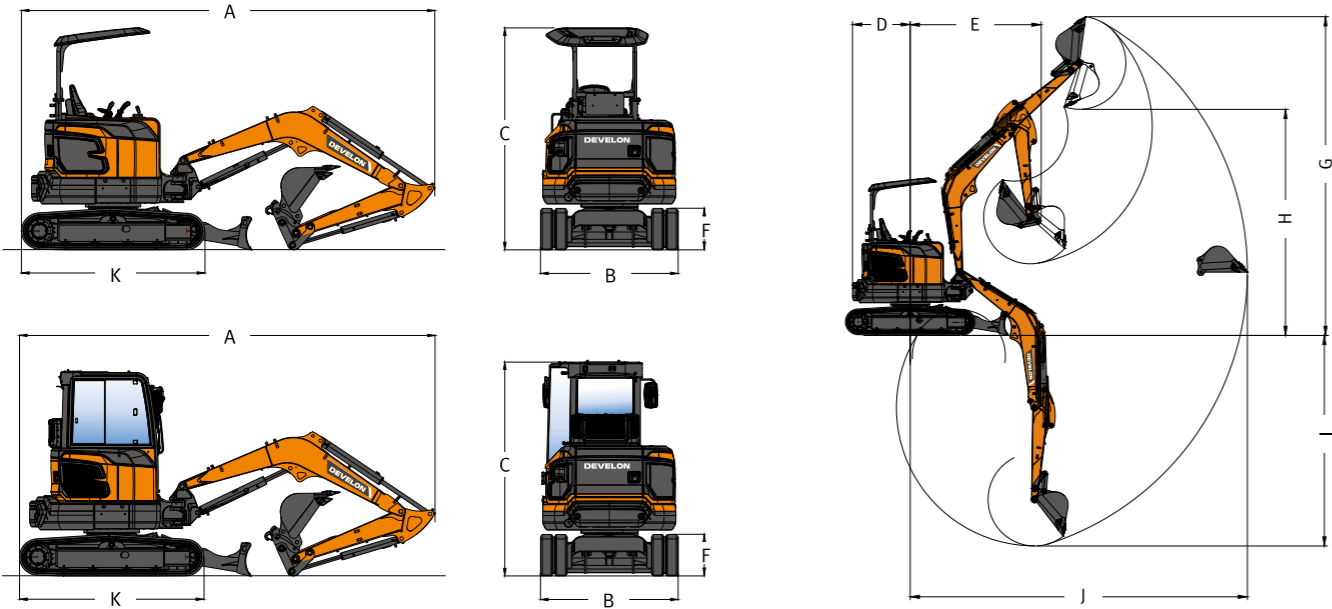

Specifications

Description		Unit	DX27Z-7M		DX35Z-7M	
			Canopy	Cabin	Canopy	Cabin
Operating weight		kg	2,770	2,875	3,987	3,995
Bucket capacity		m ³	0.08		0.11	
Engine	Model	-	Develon DN1.7		Develon DN1.7	
	Rated power	kW / rpm	18.4 / 2,400		18.4 / 2,200	
	Max. torque	kg.m / rpm	9.9 / 1,600		9.9 / 1,600	
Hydraulic	System pressure	kgf/cm ²	220		250	
	Max. flow	ℓ / min	2 X 28.8 + 19.2		2 X 37.0 + 20.7	
Performance	Travel speed (High / Low)	km/h	4.2 / 2.4		4.3 / 2.5	
	Swing speed	rpm	9.3		8.3	
	Digging force (Bucket / Arm)	ton	2.22 / 1.30		3.24 / 2.12	
	Gradeability	degree (°)	30		30	
Dimension	Overall length (A)	mm	4,191		4,780	4,791
	Undercarriage width (B)	mm	1,550		1,550	1,700
	Overall height (C)	mm	2,539	2,442	2,575	2,479
	Tail swing radius (D)	mm	855		940	875
	Min. swing radius (E)	mm	2,096		2,115	2,145
	Track height (F)	mm	451		476	
	Track length (K)	mm	1,960		2,121	
	Boom length	mm	2,090		2,535	
	Arm length	mm	1,300		1,330	1,500
Working range	Max. digging height (G)	mm	4,515		5,095	5,215
	Max. loading height (H)	mm	3,065		3,580	3,700
	Max. digging depth (I)	mm	2,845		3,275	3,445
	Max. digging reach (J)	mm	4,845		5,355	5,515
	Boom swing angle (left / right)	degree (°)	66.5 / 53.5		66.5 / 53.5	
Dozer blade (width x height)		mm	1,550 x 259		1,700 x 380	
Shoe width		mm	300		300	
Ground pressure		kgf/cm ²	0.29	0.28	0.36	0.34

develon-ce.com
HDIPBE-01-2305

©2023 HD Hyundai Infracore. All rights reserved.

DEVELON

Excavator

DX27Z-7M DX35Z-7M

Zero-tail swing excavator



WE ARE BACK WITH NEW FEATURES

PERFORMANCE

- Strong lifting and digging force
- Excellent travel performance
- Outstanding controllability reflecting customer needs
- Standard application of rotating piping
- Automatic traveling shift function applied when driving

NEW FEATURES

- New design
- Optional cabin / canopy specifications
- Zero - tail swing radius
- The boom swing function allows you to work in very narrow areas
- Boom / Arm / Bucket cylinder guard
- Canopy with tip-over protective structure (TOPS)
- Cabin with roll-over protective structure (ROPS)



CONVENIENCE AND MAINTENANCE

- Removable canopy (Canopy type)
- Front footrest in the cab (Canopy type)
- 12V power socket
- Large storage space
- Wrist rest
- Heater
- Thumb wheel joystick

DELUXE INTERIOR FOR CABIN

- Powerful air conditioner (Optional)
- Heating and cooling seat (Optional)
- Rear view camera (Optional)
- USB charging
- 5.7-inch LCD gauge panel (Optional)
- Bluetooth audio (Optional)
- DEVELON Fleet Management
- Cabin with roll-over protective structure (ROPS)
- Full glass door



HIGH PRODUCTIVITY AND LOW COST OF OWNERSHIP

- Excellent job performance based on powerful lifting and digging force.
- Delivers higher productivity and reduced fuel consumption for efficient and comfortable work environment.



Canopy type

POWERFUL HVAC SYSTEM

The operator can keep warm in a cold working environment.



EXCLUSIVELY, FOR OPERATOR.

INTEGRATED GAUGE PANEL

The integrated gauge panel allows the operator to check equipment information easily.



EQUIPPED WITH A POWERFUL ENGINE

The eco-friendly engine meets the Tier4 final and Stage V emission regulation without DPF and requires no urea solution.



ROTATING PIPING

The installed attachments expand the equipments usability.



BOOM / ARM / BUCKET CYLINDER GUARD

The boom, arm and bucket cylinder guard protects the cylinder from external impact.



AUTO - SHIFT

The auto-shift automatically shifts travel speed from high to low, depending on traction and terrain, allowing smoother operation when dozing and turning.



JOYSTICK THUMBWHEEL SWITCH

1 way, 2 way and rotating operation with the joystick thumbwheel button.



DETACHABLE CANOPY
Canopy can be removed conveniently without alteration (TOPS-certified canopy)



BOOM LED LAMP
The LED lamp with excellent illumination increases visibility.



FOOTREST
A footrest on the front of the cab is a standard feature.



BOOM SWING ANGLE

THE BOOM SWING FUNCTION ALLOWS YOU TO WORK IN VERY NARROW AREAS.



NEW CABIN FEATURES

The new cabin features ensure comfortable operation regardless of weather.

Cabin type

ROPS (ROLL-OVER PROTECTIVE STRUCTURE) CABIN

The ROPS provides protection in the event of accidental rollovers and falling objects.



ERGONOMICALLY DESIGNED WITH COMFORT IN MIND.

MECHANICAL SUSPENSION SEAT WITH HEATING

Built-in hot wires keep the operator warm and comfortable when working in cold working environments.



FULL GLASS DOOR CABIN

An unobstructed front view enables the operator to work comfortably.



REAR VIEW CAMERA

An unobstructed rear view enables the operator to work safely.



FRONT GLASS TO SLIDE OPEN

Improved work convenience



NEW DIGITAL GAUGE PANEL

The operator can check information and set functions of the equipment with the 5.7-inch color monitor.



POWERFUL HVAC SYSTEM

The high-performance air conditioner keeps the operator cool and comfortable even in the hot summer.



FRONT AND REAR WORK LIGHTS

The lights keep the work environment bright enough to ensure safe and comfortable work.



AUDIO

The Bluetooth function support allows the operator to make phone calls and listen to music.



EMERGENCY STOP SWITCH

The switch is located at the bottom of the seat to stop the engine in an emergency.



POWER SOCKET AND USB CHARGER

They can be used for charging smartphones and other devices.

DEVELON Fleet Management

The operator can check equipment information with a smartphone or a computer in real time.



LIFTING CAPACITY (DX27Z-7M)

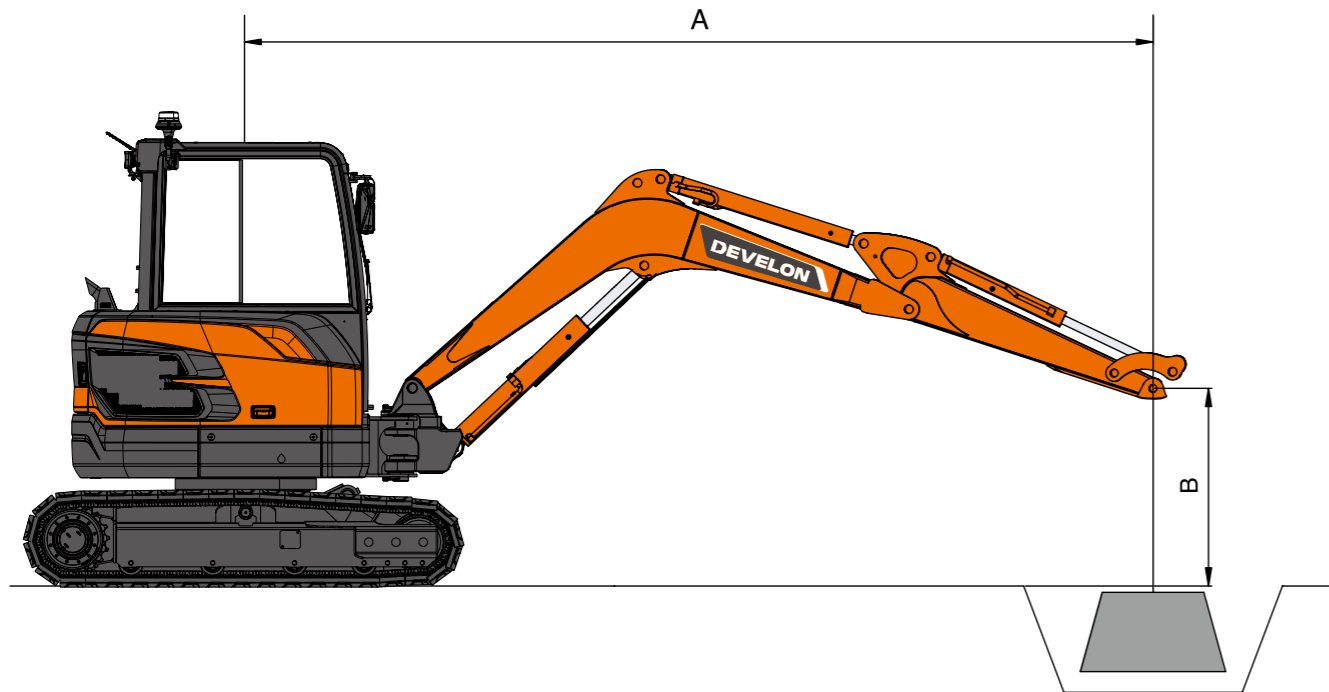

STANDARD

Dozer up

Boom : 2.09m Arm : 1.3m Shoe : 0.3m Rubber Counterweight : 60kg Unit : 1,000kg

B(m)	A(m)		1		2		3		4		Max. Reach		
	Front	Side	Front	Side	Front	Side	Front	Side	Front	Side	at (m)		
3					0.50 *	0.50 *					0.5	0.4	3.45
2					0.57 *	0.5	0.38	0.3	0.36	0.32	0.36	0.32	3.96
1					0.58	0.47			0.38	0.29	0.38	0.29	4.11
0			1.05	0.8	0.56	0.45			0.46	0.3	0.46	0.3	3.96
-1	1.55 *	1.55 *	1.06	0.81	0.56	0.44					0.37	0.37	3.43
-2			0.71 *	0.71 *					0.58 *	0.58 *	0.58 *	0.58 *	2.18

Dozer down

Unit : 1,000lb

B(m)	A(m)		1		2		3		4		Max. Reach		
	Front	Side	Front	Side	Front	Side	Front	Side	Front	Side	at (m)		
3					0.50 *	0.50 *			0.55 *	0.51	0.55 *	0.51	3.45
2					0.57 *	0.57 *			0.56 *	0.41	0.56 *	0.41	3.96
1					0.77 *	0.6	0.59 *	0.39	0.58 *	0.37	0.58 *	0.37	4.11
0			1.59 *	1.08	0.91 *	0.58			0.62 *	0.39	0.62 *	0.39	3.96
-1	1.55 *	1.55 *	1.52 *	1.08	0.84 *	0.57			0.65 *	0.48	0.65 *	0.48	3.43
-2			0.71 *	0.71 *					0.58 *	0.58 *	0.58 *	0.58 *	2.18

1. Load point is the end of the arm.
2. Capacities marked with an asterisk (*) are limited by hydraulic capacities.
3. Lift capacities shown do not exceed 75 % of minimum tipping loads or 87 % of hydraulic capacities.
4. The least stable position is over the side.
5. Lift capacities apply only to the machine as originally manufactured and normally equipped by the manufacturer.
6. Lift capacities are in compliance with iso 10567.

: Rating Over Front
 : Rating Over Side or 360 Degree

OPTION 1

Dozer up

Boom : 2.09m Arm : 1.3m Shoe : 0.3m Rubber Counterweight : 100kg Unit : 1,000kg

B(m)	A(m)		1		2		3		4		Max. Reach		
	Front	Side	Front	Side	Front	Side	Front	Side	Front	Side	at (m)		
3					0.50 *	0.50 *					0.52	0.43	3.45
2					0.57 *	0.53					0.41	0.34	3.96
1					0.61	0.5	0.4	0.32	0.38	0.31	0.38	0.31	4.11
0			1.11	0.85	0.59	0.47			0.4	0.32	0.4	0.32	3.96
-1	1.55 *	1.55 *	1.11	0.85	0.59	0.47			0.49	0.39	0.49	0.39	3.43
-2			0.71 *	0.71 *					0.58 *	0.58 *	0.58 *	0.58 *	2.18

Dozer down

Unit : 1,000lb

B(m)	A(m)		1		2		3		4		Max. Reach		
	Front	Side	Front	Side	Front	Side	Front	Side	Front	Side	at (m)		
3					0.50 *	0.50 *					0.55 *	0.54	3.45
2					0.57 *	0.57 *					0.56 *	0.43	3.96
1					0.77 *	0.63	0.59 *	0.41	0.58 *	0.39	0.58 *	0.39	4.11
0			1.59 *	1.13	0.91 *	0.61			0.62 *	0.41	0.62 *	0.41	3.96
-1	1.55 *	1.55 *	1.52 *	1.14	0.84 *	0.6			0.65 *	0.5	0.65 *	0.5	3.43
-2			0.71 *	0.71 *					0.58 *	0.58 *	0.58 *	0.58 *	2.18

1. Load point is the end of the arm.
2. Capacities marked with an asterisk (*) are limited by hydraulic capacities.
3. Lift capacities shown do not exceed 75 % of minimum tipping loads or 87 % of hydraulic capacities.
4. The least stable position is over the side.
5. Lift capacities apply only to the machine as originally manufactured and normally equipped by the manufacturer.
6. Lift capacities are in compliance with iso 10567.

: Rating Over Front
 : Rating Over Side or 360 Degree

OPTION 2

Dozer up

Boom : 2.09m Arm : 1.1m Shoe : 0.3m Rubber Non-Additional Counterweight Unit : 1,000kg

B(m)	A(m)		1		2		3		Max. Reach				
	Front	Side	Front	Side	Front	Side	Front	Side	at (m)				
3							0.57 *	0.48	0.53	0.43	0.53	0.43	3.20
2							0.58	0.47	0.4	0.32	0.4	0.32	3.76
1							0.55	0.44	0.37	0.29	0.37	0.29	3.92
0			1	0.76	0.53	0.42			0.38	0.31	0.38	0.31	3.76
-1	1.82 *	1.82 *	1.01	0.77	0.53	0.42			0.49	0.39	0.49	0.39	3.19

Dozer down

Unit : 1,000lb

B(m)	A(m)		1		2		3		Max. Reach				
	Front	Side	Front	Side	Front	Side	Front	Side	at (m)				
3							0.57 *	0.57 *	0.60 *	0.55	0.60 *	0.55	3.20
2							0.63 *	0.6	0.60 *	0.42	0.60 *	0.42	3.76
1							0.81 *	0.57	0.62 *	0.38	0.62 *	0.38	3.92
0			1.59 *	1.03	0.91 *	0.55			0.65 *	0.4	0.65 *	0.4	3.76
-1	1.82 *	1.82 *	1.41 *	1.04	0.79 *	0.55			0.68 *	0.51	0.68 *	0.51	3.19

1. Load point is the end of the arm.
2. Capacities marked with an asterisk (*) are limited by hydraulic capacities.
3. Lift capacities shown do not exceed 75 % of minimum tipping loads or 87 % of hydraulic capacities.
4. The least stable position is over the side.
5. Lift capacities apply only to the machine as originally manufactured and normally equipped by the manufacturer.
6. Lift capacities are in compliance with iso 10567.

: Rating Over Front
 : Rating Over Side or 360 Degree

LIFTING CAPACITY (DX35Z-7M)

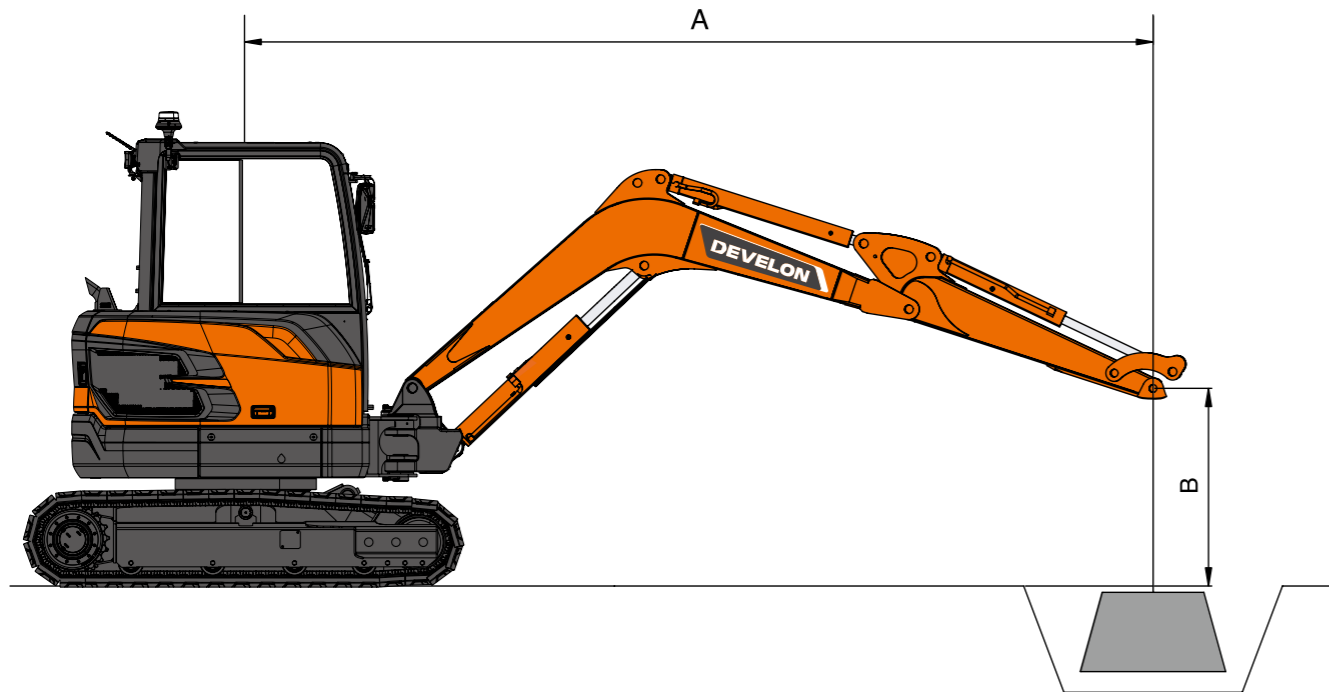

STANDARD

Dozer up

Boom : 2.54m Arm : 1.33m Shoe : 0.3m Rubber Non-Additional Counterweight Unit : 1,000kg

B(m)	A(m)		1		2		3		4		Max. Reach		
	🏗️	🏗️	🏗️	🏗️	🏗️	🏗️	🏗️	🏗️	🏗️	🏗️	🏗️	at (m)	
4					0.91 *	0.86					0.89	0.78	3.16
3					0.85 *	0.85 *	0.61	0.53	0.6	0.52	0.6	0.52	4.05
2					0.94	0.82	0.6	0.53	0.5	0.44	0.5	0.44	4.47
1					0.89	0.77	0.58	0.51	0.47	0.41	0.47	0.41	4.59
0			1.52 *	1.36	0.86	0.74	0.57	0.49	0.49	0.43	0.49	0.43	4.45
-1	2.11 *	2.11 *	1.67	1.38	0.85	0.74			0.57	0.5	0.57	0.5	3.99
-2			1.72	1.43	0.89	0.77			0.87	0.75	0.87	0.75	3.06

Dozer down

Unit : 1,000lb

B(m)	A(m)		1		2		3		4		Max. Reach		
	🏗️	🏗️	🏗️	🏗️	🏗️	🏗️	🏗️	🏗️	🏗️	🏗️	🏗️	at (m)	
4					0.91 *	0.91 *			0.95 *	0.95 *	0.95 *	0.95 *	3.16
3					0.85 *	0.85 *	0.91 *	0.91 *	0.80 *	0.80 *	0.80 *	0.80 *	4.05
2					1.12 *	1.12 *	0.94 *	0.94 *	0.77 *	0.77 *	0.77 *	0.77 *	4.47
1					1.50 *	1.50 *	1.07 *	1.07 *	0.80 *	0.80 *	0.80 *	0.80 *	4.59
0			1.52 *	1.52 *	1.70 *	1.70 *	1.15 *	1.15 *	0.91 *	0.91 *	0.91 *	0.91 *	4.45
-1	2.11 *	2.11 *	2.72 *	2.72 *	1.62 *	1.62 *			1.03 *	1.03 *	1.03 *	1.03 *	3.99
-2			1.85 *	1.85 *	1.05 *	1.05 *			0.99 *	0.99 *	0.99 *	0.99 *	3.06

1. Load point is the end of the arm.
 2. Capacities marked with an asterisk (*) are limited by hydraulic capacities.
 3. Lift capacities shown do not exceed 75 % of minimum tipping loads or 87 % of hydraulic capacities.
 4. The least stable position is over the side.
 5. Lift capacities apply only to the machine as originally manufactured and normally equipped by the manufacturer.
 6. Lift capacities are in compliance with iso 10567.
- 🏗️ : Rating Over Front
🏗️ : Rating Over Side or 360 Degree

OPTION 1

Dozer up

Boom : 2.54m Arm : 1.33m Shoe : 0.3m Rubber Counterweight : 100kg Unit : 1,000kg

B(m)	A(m)		1		2		3		4		Max. Reach		
	🏗️	🏗️	🏗️	🏗️	🏗️	🏗️	🏗️	🏗️	🏗️	🏗️	🏗️	at (m)	
4					0.91 *	0.78					0.95	0.71	3.16
3					0.85 *	0.79	0.65	0.49	0.63	0.48	0.63	0.48	4.05
2					1	0.75	0.64	0.48	0.53	0.4	0.53	0.4	4.47
1					0.94	0.69	0.62	0.46	0.5	0.38	0.5	0.38	4.59
0			1.52 *	1.21	0.91	0.67	0.6	0.45	0.52	0.39	0.52	0.39	4.45
-1	2.11 *	2.11 *	1.78	1.22	0.91	0.66			0.61	0.45	0.61	0.45	3.99
-2			1.83	1.27	0.95	0.7			0.92	0.68	0.92	0.68	3.06

Dozer down

Unit : 1,000lb

B(m)	A(m)		1		2		3		4		Max. Reach		
	🏗️	🏗️	🏗️	🏗️	🏗️	🏗️	🏗️	🏗️	🏗️	🏗️	🏗️	at (m)	
4					0.91 *	0.91 *			0.95 *	0.95 *	0.95 *	0.95 *	3.16
3					0.85 *	0.85 *	0.91 *	0.91 *	0.80 *	0.80 *	0.80 *	0.80 *	4.05
2					1.12 *	1.12 *	0.94 *	0.94 *	0.77 *	0.77 *	0.77 *	0.77 *	4.47
1					1.50 *	1.50 *	1.07 *	1.07 *	0.80 *	0.80 *	0.80 *	0.80 *	4.59
0			1.52 *	1.52 *	1.70 *	1.70 *	1.15 *	1.15 *	0.91 *	0.91 *	0.91 *	0.91 *	4.45
-1	2.11 *	2.11 *	2.72 *	2.72 *	1.62 *	1.62 *			1.03 *	1.03 *	1.03 *	1.03 *	3.99
-2			1.85 *	1.85 *	1.05 *	1.05 *			0.99 *	0.99 *	0.99 *	0.99 *	3.06

1. Load point is the end of the arm.
 2. Capacities marked with an asterisk (*) are limited by hydraulic capacities.
 3. Lift capacities shown do not exceed 75 % of minimum tipping loads or 87 % of hydraulic capacities.
 4. The least stable position is over the side.
 5. Lift capacities apply only to the machine as originally manufactured and normally equipped by the manufacturer.
 6. Lift capacities are in compliance with iso 10567.
- 🏗️ : Rating Over Front
🏗️ : Rating Over Side or 360 Degree

OPTION 2

Dozer up

Boom : 2.54m Arm : 1.5m Shoe : 0.3m Rubber Counterweight : 100kg Unit : 1,000kg

B(m)	A(m)		1		2		3		4		Max. Reach		
	🏗️	🏗️	🏗️	🏗️	🏗️	🏗️	🏗️	🏗️	🏗️	🏗️	🏗️	at (m)	
4					0.79 *	0.79 *					0.82 *	0.74	3.42
3					0.77 *	0.77 *	0.65	0.58	0.59	0.52	0.59	0.52	4.24
2							1.48 *	1.48 *	1.01	0.88	0.64	0.56	4.64
1									0.95	0.82	0.62	0.54	4.76
0			1.57 *	1.45	0.91	0.79	0.6	0.53	0.49	0.43	0.49	0.43	4.62
-1	1.89 *	1.89 *	1.76	1.46	0.91	0.78	0.6	0.53	0.57	0.5	0.57	0.5	4.19
-2			1.81	1.5	0.93	0.8			0.81	0.7	0.81	0.7	3.33

Dozer down

Unit : 1,000lb

B(m)	A(m)		1		2		3		4		Max. Reach		
	🏗️	🏗️	🏗️	🏗️	🏗️	🏗️	🏗️	🏗️	🏗️	🏗️	🏗️	at (m)	
4					0.79 *	0.79 *			0.82 *	0.82 *	0.82 *	0.82 *	3.42
3					0.77 *	0.77 *	0.83 *	0.83 *	0.69 *	0.69 *	0.69 *	0.69 *	4.24
2							1.48 *	1.48 *	1.04 *	1.04 *	0.90 *	0.90 *	4.64
1									1.44 *	1.44 *	1.04 *	1.04 *	4.76
0			1.57 *	1.57 *	1.68 *	1.68 *	1.14 *	1.14 *	0.79 *	0.79 *	0.79 *	0.79 *	4.62
-1	1.89 *	1.89 *	2.85 *	2.85 *	1.65 *	1.65 *	1.08 *	1.08 *	0.98 *	0.98 *	0.98 *	0.98 *	4.19
-2			2.08 *	2.08 *	1.23 *	1.23 *			0.98 *	0.98 *	0.98 *	0.98 *	3.33

1. Load point is the end of the arm.
 2. Capacities marked with an asterisk (*) are limited by hydraulic capacities.
 3. Lift capacities shown do not exceed 75 % of minimum tipping loads or 87 % of hydraulic capacities.
 4. The least stable position is over the side.
 5. Lift capacities apply only to the machine as originally manufactured and normally equipped by the manufacturer.
 6. Lift capacities are in compliance with iso 10567.
- 🏗️ : Rating Over Front
🏗️ : Rating Over Side or 360 Degree